



# Operating Manual BKS015

Steering Frame with Integrated Digital Controller  
for Web Guiding

|                  |      |            |
|------------------|------|------------|
| Version          | 1.81 | 11/2018 NS |
| Firmware Version | 1.71 |            |



Diese Bedienungsanleitung ist auch in Deutsch erhältlich.  
Bitte kontaktieren Sie Ihren nächstgelegenen FMS Vertreter.

## Table of Contents

---

|           |  |           |
|-----------|--|-----------|
| <b>1</b>  | <b>Safety Instructions .....</b>                       | <b>2</b>  |
| 1.1       | Description Conditions                                 | 2         |
| 1.2       | List of Safety Instructions                            | 3         |
| <b>2</b>  | <b>System Description .....</b>                        | <b>4</b>  |
| 2.1       | Functional Description                                 | 4         |
| 2.2       | Steering Frame   | 4         |
| 2.3       | Web Guide Controller                                   | 4         |
| 2.4       | Sensors  | 5         |
| 2.5       | Cables   | 5         |
| <b>3</b>  | <b>Quick Installation Guide.....</b>                   | <b>6</b>  |
| 3.1       | Preparations for Set-up                                | 6         |
| 3.2       | Installation Procedure                                 | 6         |
| <b>4</b>  | <b>Installation and Wiring .....</b>                   | <b>7</b>  |
| 4.1       | Mounting the Steering Frame                            | 7         |
| 4.2       | Mounting the Sensors                                   | 7         |
| 4.3       | Connecting the BKS015                                  | 8         |
| 4.4       | Connector and Screw Terminal Arrangement               | 8         |
| <b>5</b>  | <b>Configuring the System.....</b>                     | <b>10</b> |
| 5.1       | Powering up the BKS015                                 | 10        |
| 5.2       | Adjustment of the Sensors                              | 10        |
| <b>6</b>  | <b>Operation .....</b>                                 | <b>10</b> |
| 6.1       | Operation Panel  | 10        |
| 6.2       | Basic Instructions for Operation and Parameter Setting | 11        |
| 6.3       | Operating the Web Guiding System via the Front Panel   | 11        |
| 6.4       | Operation in Automatic Mode                            | 12        |
| 6.5       | Operation in Manual Mode                               | 13        |
| 6.6       | Entering the Parameter Setting Mode                    | 13        |
| 6.7       | Description of the LED-row                             | 14        |
| 6.8       | Sensor Detection Range and Reference Position          | 15        |
| <b>7</b>  | <b>Description Parameters .....</b>                    | <b>15</b> |
| 7.1       | Description Operation Parameters                       | 15        |
| 7.2       | Description of System Parameters                       | 20        |
| 7.3       | Reset to Default Parameter Set                         | 21        |
| <b>8</b>  | <b>Parameter Setting via a PC.....</b>                 | <b>22</b> |
| 8.1       | Parameterization in a Network via Web Browser          | 24        |
| 8.2       | Parameterization via a PC (peer-to-peer connection)    | 28        |
| <b>9</b>  | <b>Mechanical Dimensions.....</b>                      | <b>32</b> |
| <b>10</b> | <b>Trouble Shooting.....</b>                           | <b>34</b> |
| <b>11</b> | <b>Technical Specification .....</b>                   | <b>35</b> |

# 1 Safety Instructions

## 1.1 Description Conditions

- a) Danger of health injury or loss of life



### **Danger**

*This symbol refers to high risk for persons to get health injury or loss life. It has to be followed strictly.*

b) Risk of damage of machines



### **Caution**

*This symbol refers to information, that, if ignored, could cause heavy mechanical damage. This warning has to be followed absolutely.*

c) Note for proper function



### **Note**

*This symbol refers to an important information about proper use. If not followed, malfunction can be the result.*

## 1.2 List of Safety Instructions

- ⚠** *Proper function of the FMS web guide is only guaranteed with the recommended application of the components. In case of other arrangement, heavy malfunction can be the result. Therefore, the installation instructions on the following pages must be followed strictly.*
- ⚠** *Local installation regulations are to preserve safety of electric equipment. They are not taken into consideration by this operating manual. However, they have to be followed strictly.*
- ⚠** *Make sure that the sensor(s) are connected properly to the electronic unit by means of the delivered cables. For left / right orientation please refer to Fig. 2. If the connections are crossed over, malfunction can be the result.*
- ⚠** *System parameters are factory settings and should not be changed without contacting the service department of FMS. An unauthorised change can cause malfunctions in the system or damage in the machine*

## 2 System Description

### 2.1 Functional Description

**Figure 1** shows a typical web guiding system with its basic components. The sensors measure the position of the web edge and send this information as an analogue signal to the built-in web guide controller unit. The control compares the position feedback signal with the reference. If the difference of these two values is higher than the stored dead band value, the steering frame will be adjusted.

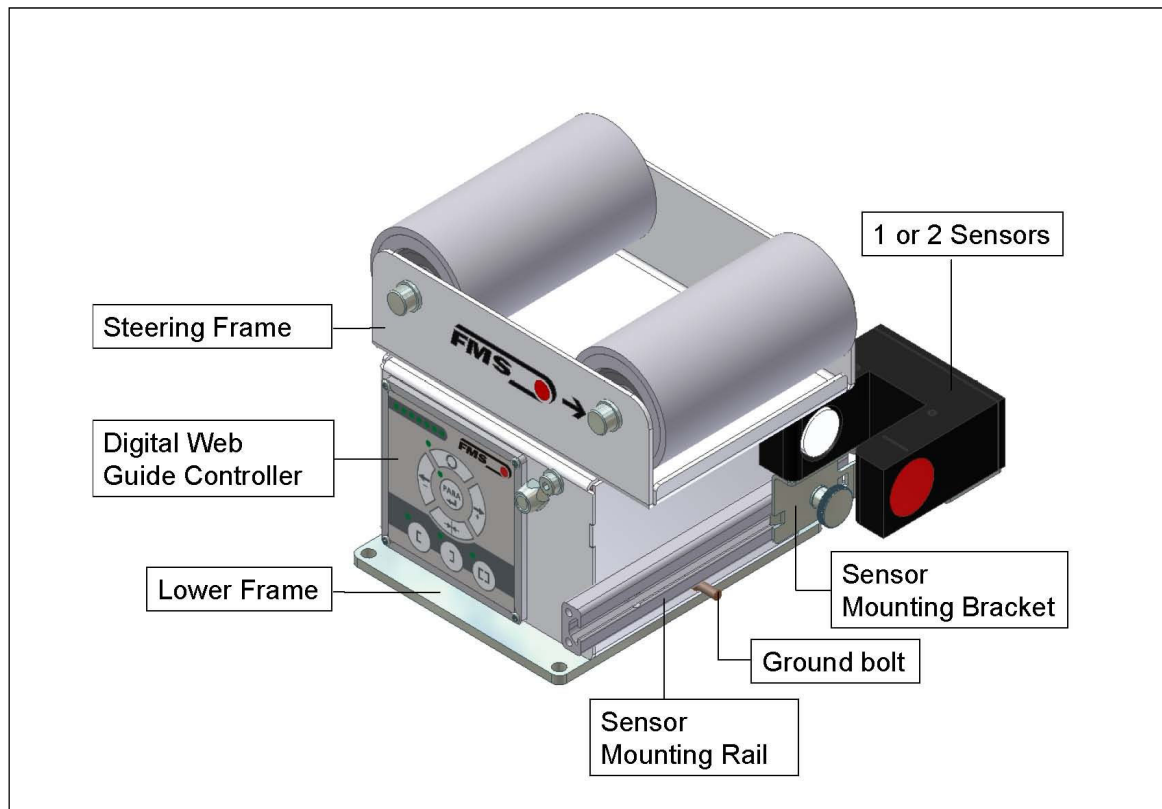

Fig. 1: Basic BKS015 system

K015006e

### 2.2 Steering Frame

The steering frame consists of a fixed lower and a moveable upper frame that supports the rollers. The upper frame is activated by a stepper motor. The rollers are manufactured and balanced according to customer specification. End positions are controlled by hall sensors. The material sensors are mounted on the lower frame by means of a bracket array and are easily adjustable to the web width.

### 2.3 Web Guide Controller

The micro-processor based electronic control unit handles all calculations and communications tasks. Three buttons and a five key wind-rose serve as the man-machine interface. Parameter setting can be performed via the front panel keys or through a Web Browser (IE 7.0 or higher). The controller is then either connected to a network (e.g. Ethernet) or via a peer-to-peer configuration to a laptop or local PC. All parameters are stored in a non-volatile EEPROM memory.

## 2.4 Sensors

Optical sensors (**AZS04**) and ultrasonic sensors (**US01B**) are available from FMS to work in conjunction with the BKS015 system. These sensors provide a signal of 0...10V. With them edge and center applications can be covered. A wide range of materials including opaque, transparent, open weave textiles and metallic webs can be detected.

## 2.5 Cables

The power supply cable enters to the web guide via a PG-gland connection. For each sensor a dedicated orange cable is delivered.

## 3 Quick Installation Guide

The set-up of the BKS015 web guide including controller unit is limited to only mounting the devices on the machine frame, wiring and powering up system.

### 3.1 Preparations for Set-up

- Prepare your machine frame to integrate the BKS015 web guide. The web guide is mounted on the machine by means of the 4 holes on its base plate. Refer to **Fig. 21** for the mechanical dimensions and mounting holes of the BKS015.
- Check your system requirements such as:
  - Desired guiding form (edge or centre guiding)
  - Supply conditions
- Draw the wiring diagram for your configuration (ref. to **4.3** “Connecting the BKS015“ and chapter 4.4 “Connector and Screw Terminal Arrangement”)
- If required, determine special parameters (ref. to 7.1 “Description Operation Parameters”)

### 3.2 Installation Procedure

1. Mount and adjust your material sensor(s) to the steering frame (ref. to chapter **4.2**)
2. Mount the web guide to the machine frame
3. Connect the sensor(s) to the electronic unit.
4. Make sure the power supply voltage is in the range 18 to 36V DC ( $V_{nom} = 24V$ )
5. Power your system on
6. If required, make additional settings (ref. also to chapters **6.4** to **6.8**)

## 4 Installation and Wiring



### Caution

*Proper function of the FMS web guides and actuators is only guaranteed with the recommended application of the components. Other arrangements can cause heavy malfunctions. Therefore, the installation instructions on the following pages must strictly be followed.*



### Caution

*Local installation regulations are to preserve safety of electric equipment. They are not taken into consideration by this operating manual. However, they have to be followed strictly.*

### 4.1 Mounting the Steering Frame

The mounting orientation of the steering frame (indicated by an arrow), must correspond with the web running direction. The lower frame is mounted with four M5 screws to the machine frame. The machine must be prepared to accept the M5 mounting screws.

The steering frame must be connected to earth ground. Ensure that the base plate of the steering frame has direct contact with the grounded machine frame. In addition the ground bolt (see **Fig. 1**) must be connected to the machine earth.



### Caution

*Bad earth connection may cause electric shock to persons, malfunction of the total system or damage of the control unit. It is vital to ensure that there is a proper and secure earth connection.*

### 4.2 Mounting the Sensors

The sensors will be mounted with brackets on a rail to the lower frame of the web guide

They have to be installed after the outbound roller. Mount them as close as possible to the steering frame (see **Fig. 2**). The sensors are connected to the web guide controller by means of the delivered orange cables. Refer to the operation manual AZS01, US01B for further information about the sensors.

**Definition of Left and Right:**

Left and right are always seen in direction of the running web (see Fig. 2).

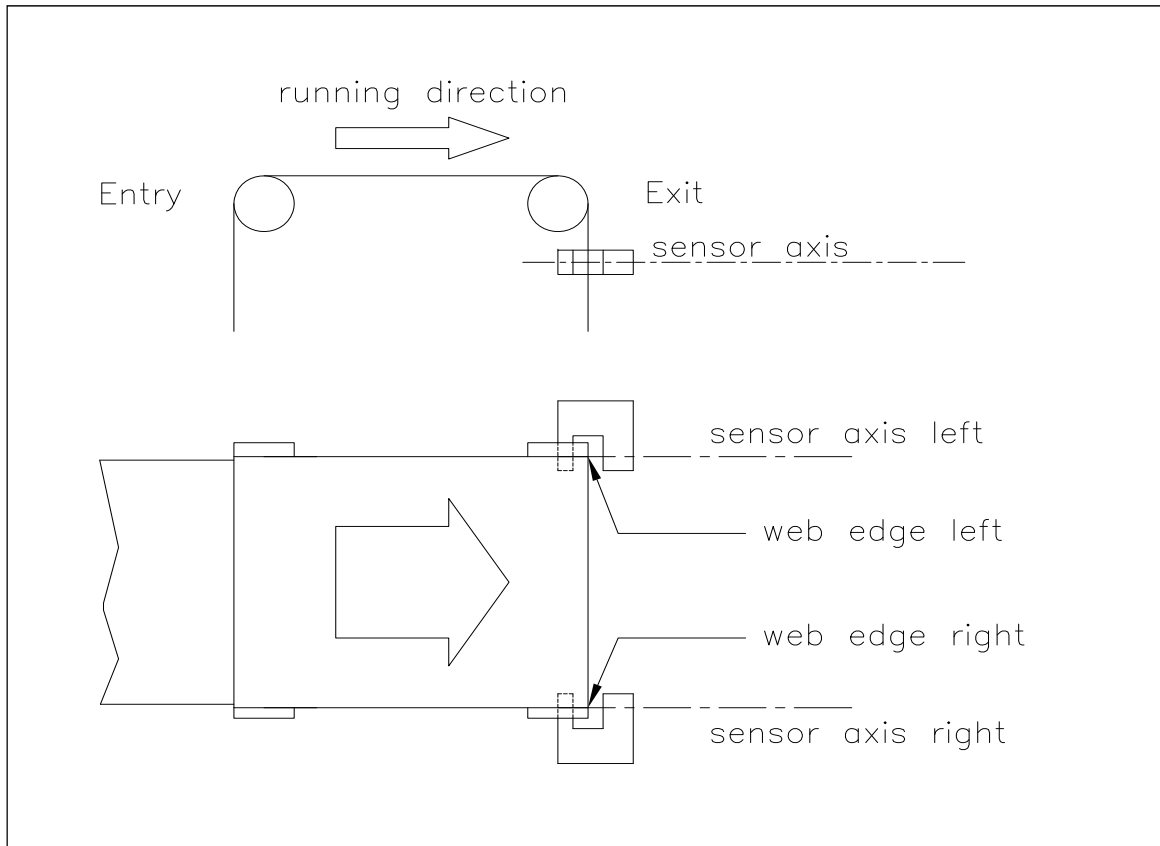



Fig. 2: Position of the sensors according to the web

K400005e

Sensors of the type AZS must be mounted with its narrow side (thinner leg) on the side of the steering frame



**Caution**  
*Make sure that the sensor(s) are connected properly to the electronic unit by means of the delivered orange cables. For left / right orientation please refer to Fig. 2. If the connections are crossed over, malfunction can be the result.*

### 4.3 Connecting the BKS015

The power supply unit must deliver a voltage from 18 to 36V DC (Vnom= 24V). Connect the cable coming out of the PG-gland to your power supply unit.

| Wire colour | Signal |
|-------------|--------|
| brow        | 24 VDC |
| blue        | GND    |

### 4.4 Connector and Screw Terminal Arrangement

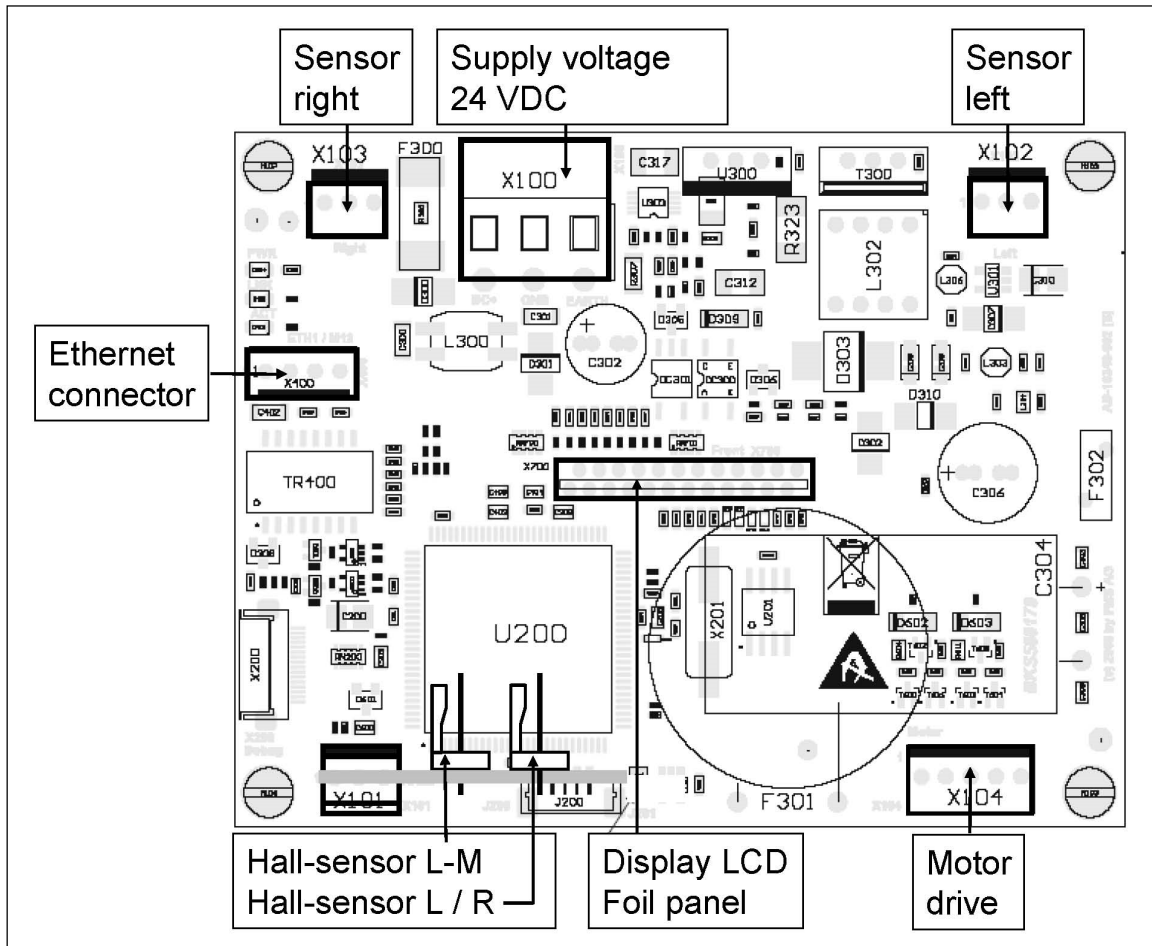

Fig. 3: Terminal arrangement on processor board

K015008e

## 5 Configuring the System

After having mounted and wired the web guide on the machine, the system can now be configured to the specific requirements of the application.

### 5.1 Powering up the BKS015

1. Make sure the power supply delivers a voltage of 18...36 VDC ( $V_{nom} = 24V$ )
2. Check, if the web is in the detection range of the sensors.
3. Switch-on your power supply
4. The web guide starts-up in Manual Operating Mode.

### 5.2 Adjustment of the Sensors

Align sensor axis to the web edge:

Loosen the fixing nut on the bracket and adjust the sensor. Fix the sensor in the new position. The sensor will be properly positioned, if the web edge goes through the sensor axis (center of active window; ref. to **Fig. 4**).

**Fig 4:** Alignment of the sensor axis to the web edge

K100004e

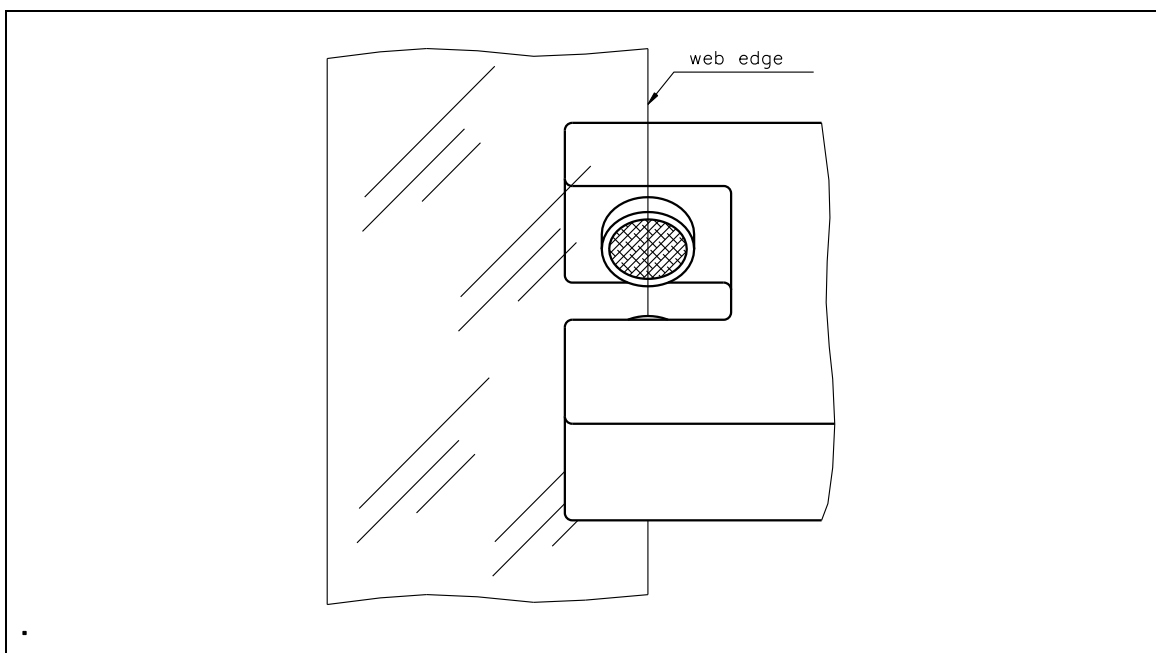

## 6 Operation

### 6.1 Operation Panel

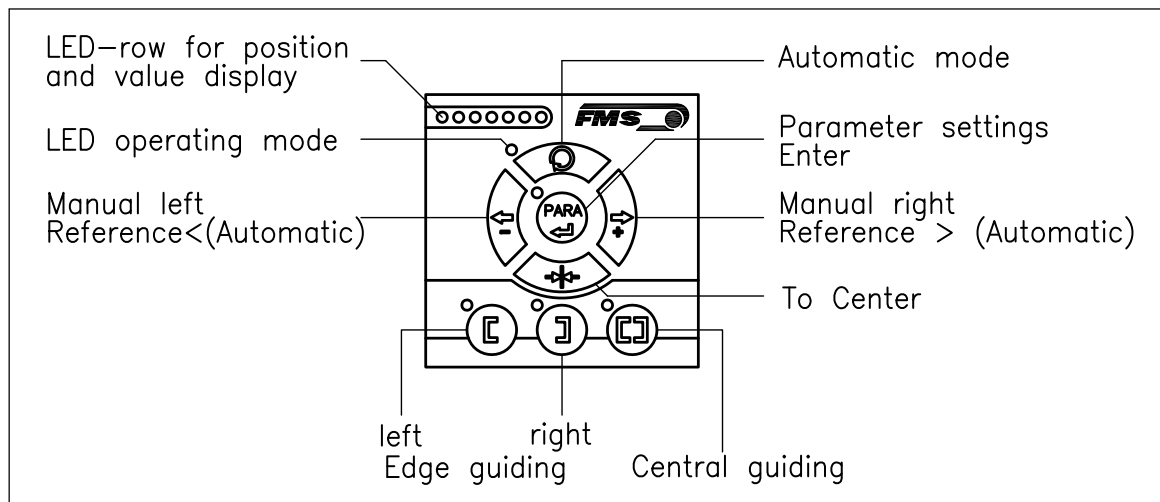

Fig. 5: View of the Operation Panel

K015003e

## 6.2 Basic Instructions for Operation and Parameter Setting

The web guide controller has three operation mods:

- Operation Mode
- Parameter Setting Mode (e.g. Dead Band)
- Change Mode (change of Reference Position)

Parameter setting can be performed via the keys on the front panel or via a web browser. When using the front panel, the user can toggle between these modi by pressing the corresponding key or key combination. The Parameters are described in chapter 7.1 “Description of Operation Parameters”). The keys have the following functions:

| Key | Key function during parameter setting  |
|-----|--|
|     | Enter  |
|     | Increase or decrease the values.<br>Permanent pressing of the keys expedites the changing speed. |

**Note**  
To make the settings easier for the operator, there is visual help in form of LED row. The pattern on the LED row indicates the setting range (ref. to chapter 6.7 “Description of the LED row).

## 6.3 Operating the Web Guiding System via the Front Panel

| Key | Key function during operation   |
|-----|---|
|     | The sensor is mounted on the left side of the frame and controls the material on the left edge or on the line, if a line sensor is used. One sensor is necessary. The LED indicates the left edge guiding mode. |







|   |   |
|---|---|
|    | <p>The sensor is mounted on the right side of the frame and controls the material on right edge or on the line, if a line sensor is used. One sensor is necessary. The LED indicates the right edge guiding mode.</p>   |
|    | <p>Two sensors are mounted on both sides of the frame. The frame is controlled in a way that the material position is kept centered with regard to both sensor positions. The LED indicates the centre guiding mode.</p>  |
|    | <p>Key to enter the Parameter Setting Mode. Hold the key for longer then 3 sec. The LED above the PARA key lights. A second press for longer then 3 sec. on the PARA key will store the value (ref. to 6.6 “Entering the Parameter Setting”)</p>  |
|    | <p>With this key you can select between automatic or manual mode. The LED indicates the automatic mode.</p>   |
|    | <p>Drive to center position. The frame moves to the center Position. This function is only available in manual mode.</p>  |
|   | <p><b>In manual mode</b> the frame will move to the left in 0.1mm steps by pressing the button once. By pressing the button longer than 1 sec. it will continuously move the frame to the left.<br/> <b>In automatic mode</b> the Reference Position will be adjusted to the left in 0.1 mm steps by pressing the button once. Pressing the button longer than 1 sec. it will continuously move the Reference Position to the left (see chapter 6.4)<br/> <b>In parameter setting mode:</b> Pressing the button reduces continuously the parameter value.</p>           |
|  | <p><b>In manual mode</b> the frame will move to the right in 0.1mm steps by pressing the button once. By pressing the button longer than 1 sec. it will continuously move the frame to the right.<br/> <b>In automatic mode</b> the Reference Position will be adjusted to the right in 0.1 mm steps by pressing the button once. Pressing the button longer than 1 sec. it will continuously move the Reference Position to the right. (see chapter 6.4) “.<br/> <b>In parameter setting mode:</b> Pressing the button increases continuously the parameter value.</p> |







Fig. 6: Table of key functions

## 6.4 Operation in Automatic Mode

In Automatic Mode the web guide controller starts to guide the web to the Reference Position and to hold this guiding point.

For edge guiding operations the Reference Position is in the middle of the sensor detection range (**Fig. 7**). For centre guiding the Reference Position is in the middle between the two sensor axis.

This Reference Position can be adjusted as follows:

- Start automatic mode with the  key.
- The Reference Position can be adjusted in 0.1mm steps by using the  and  keys.
- For left sensor operation the  key causes the web moving inside the sensor. The  key causes the web moving outside the sensor. Using right sensor operation or center guiding the setting behaves contrariwise (refer also to **Fig. 10, 11 and 12**)
- Terminate the automatic mode by using the  key again.

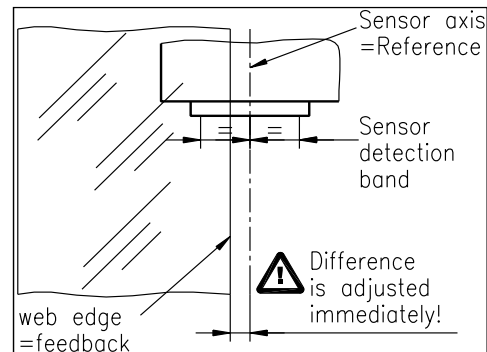

**Fig. 7:** Reference position at automatic start K100005e



### Caution

*If web is not running, it can't be guided properly to the Reference Position. The steering frame moves in the limit-of-travel position and may damage the web. Start automatic mode only when web is slowly running*





### Note

*If the web leaves the sensor detection range, control is no longer effective. Hold the web edge strictly inside the sensor detection band.*

## 6.5 Operation in Manual Mode

In Manual Mode several operations and settings can be carried out (see **Fig. 6**):

- **Center position** : The steering frame will return to center position.
- **Frame position**  and : The steering frame can be adjusted in 0.1mm steps. If key is held, the steering frame will move continuously to chosen direction.
- **Parameter Setting Mode:** The Parameter Setting Mode can only be entered in Manual Operation.

## 6.6 Entering the Parameter Setting Mode

To enter the Parameter Setting Mode the web guide controller must be in the Manual Mode. In the Automatic Mode only the reference value can be changed.

- Press the key for longer then 3 sec. The LED above the key will light indicating that the controller entered the Parameter Setting Mode. In this mode the Dead Band parameter can be adjusted (see chapter 7 “Description of Operation Parameters”)
- With the keys and the desired band can be adjusted (see Fig. 9)
- Press the key again to confirm the setting and leave the Parameter Setting Mode.

## 6.7 Description of the LED-row

= LED illuminated

= LED off

a) Automatic or manual mode. LED control of web position

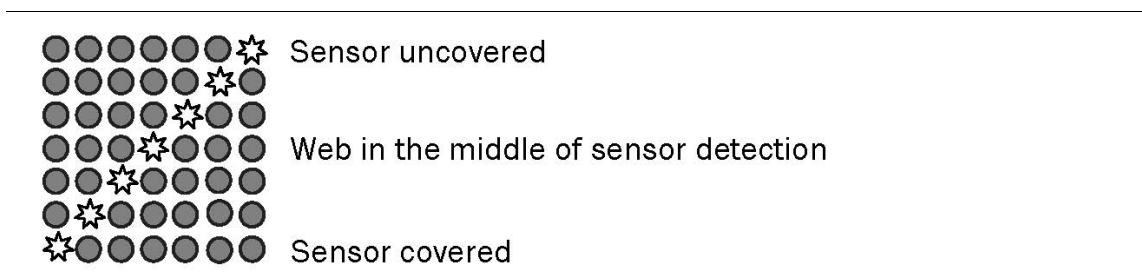

Fig 8: LED row indicates material position

K015004e

b) Setup mode for the adjustment of Dead Band

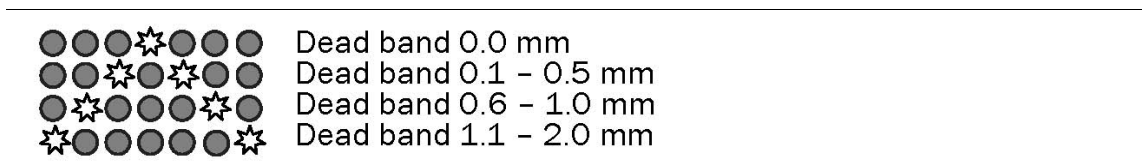

Fig 9: LED indication of Dead Band values

K015005e

c) Setup mode for the adjustment of the Reference Position for left sensor operation. Setup is only possible in automatic mode with the direction keys.

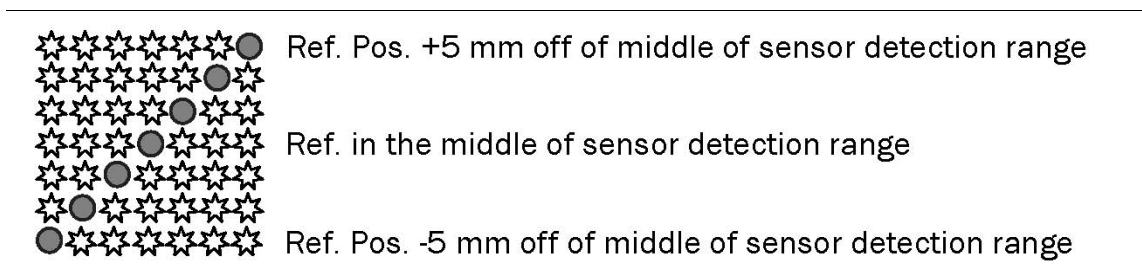

Fig 10: LED indication of Reference Position values (left sensor)

K015013e

d) Setup mode for the adjustment of the Reference Position for right sensor operation and center guiding. Setup is only possible in automatic mode with the direction keys.

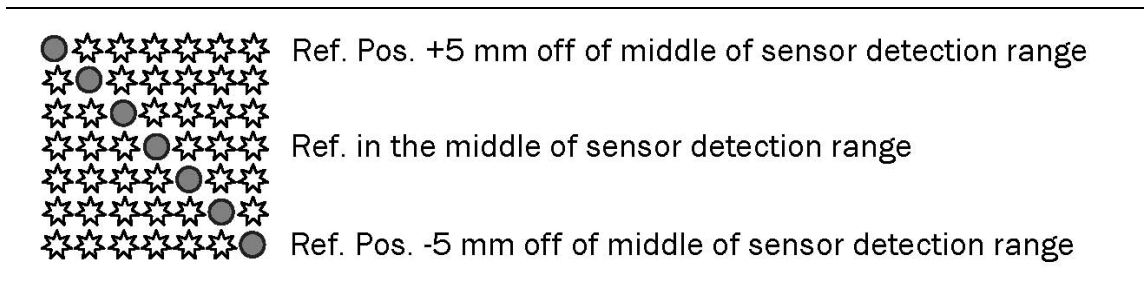

Fig 11: LED indication Reference Position values (right sensor)

K015014e

## 6.8 Sensor Detection Range and Reference Position

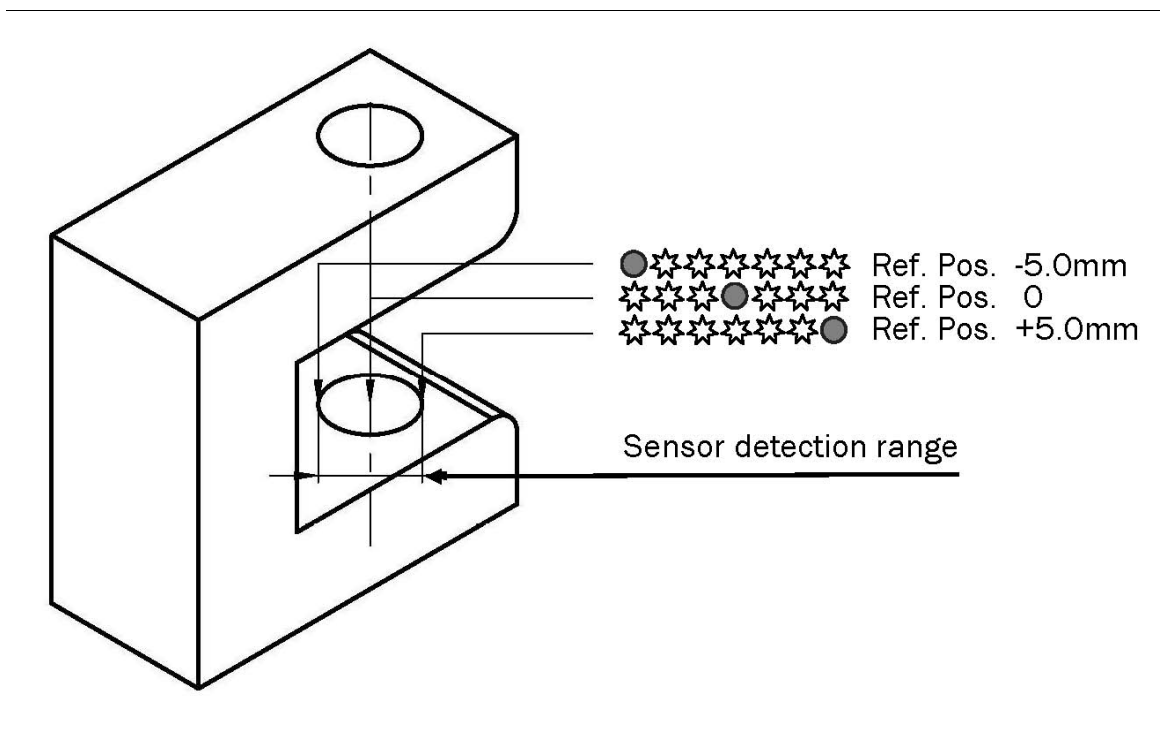

Fig. 12: View of the Sensor Detection Range

K015007e

# 7 Description Parameters

## 7.1 Description Operation Parameters



### Note

The first three parameters [RefPos], [RefMode] and [DeadBand] in the parameter list below can be changed via the front panel (ref. to chapters 6.4 to 6.8). All other parameters can only be accessed and changed via the build-in web browser (ref. to chapter 8 "Parameter Setting via a PC")



### Adjusting Reference Position [Ref Pos]

**Purpose:** The [RefPos] parameter determines the reference position within the sensor detection range. This reference point can also be

adjusted over the front panel as described in chapter 6.2 “Automatic Operation”. The Reference Position is kept stored until the next power-on.

Range: -5.0 to +5.0 Default: 0.0  
 Increment: 0.1 Unit: [mm]

 **Note**

By pressing the keys  and  at the same time for longer then 1 sec., the Reference Position will reset to default

**Setting Reference Mode [Ref Mode]**

**Purpose:** This parameter determinates how the Reference Position is defined. This can either be the position that is defined with parameter [Ref Pos] or the actual material position within the sensor when the controller is switched to automatic operation.

**Two settings are possible:**

**Setting:** **[Manual]**

**Purpose:** If [Manual] is chosen, the reference is taken from the parameter [RefPos].

**Setting:** **Automatic [Auto]**

**Purpose:** If [Auto] behaviour is chosen then the reference is determent by taking the actual material position within the sensor when the controller is switched to automatic operation.



### Adjusting Correction Speed [AdjSpeed]

|                   |  |     |                     |
|-------------------|--|-----|---------------------|
| <b>Purpose:</b>   | This parameter determines the maximum used correction speed. |     |                     |
| <b>Range:</b>     | 1 bis  | 100 | <b>Default:</b> 100 |
| <b>Increment:</b> | 1  |     | <b>Unit:</b> [%]    |

### Power Modes [Power ON]

**Purpose:** This parameter determines the operation mode after power on.

The user can choose between three behaviours.

**Setting:** **[Manual]**

**Purpose:** The controller goes to Manual Operation Mode after power on.

**Setting:** **Automatic [Auto]**

**Purpose:** The controller goes to Automatic Operation Mode after power on.

**Setting:** **Last Setting Used [Last Set]**

**Purpose:** The controller restores the operation mode that was previously chosen before power off.

### Behaviour when leaving Automatic Mode [Auto→Man]

**Purpose:** This parameter determines the behaviour of the controller leaving the automatic mode.

The user can choose between two behaviours.

**Setting:** **[Manual]**

**Purpose:** The controller stops guiding. The web guide is locked at the current position (Manual Mode).

**Setting:** **[Centre]**

**Purpose:** The controller stops guiding. Afterwards the web guide moves to the centre.



## 7.2 Description of System Parameters



### Caution

*System parameters are factory settings and should not be changed without contacting the service department of FMS. An unauthorised change can cause malfunctions in the system or damage in the machine.*

### Offset Centre [Offset><]

**Purpose:** This parameter adjusts the position of a steering frame exactly to the centre.

**Type:** [One Hall]

**Purpose:** One hall sensor is used to detect the Home position, Middle Position and Maximum Position.

**Type:** [Two Hall]

**Purpose:** Two hall sensors are used to detect the Home position, Middle Position and Maximum Position.

### Centre Position [CentrPos]

**Purpose:** The [CentrPos] parameter is only used with the position detection system based on hall sensors. For all other position detection system this parameter is not used and hence not displayed. The parameter determines the centre position of the actuator spindle in motor steps (measured from the left reference position). The actuator stops at this position, if you press the centre key . In Automatic Operation this parameter has no meaning.

**Range:** 0 to 10'000 **Default:** Factory setting

**Increment:** 1 **Unit:** [Step]

### Right Limit [RightLim]

|                   |  |                 |                 |
|-------------------|--|-----------------|-----------------|
| <b>Purpose:</b>   | The [RightLim] parameter is only used with the position detection system based on hall sensors. For all other position detection system this parameter is not used and hence not displayed. The parameter limits the maximum travel to the right side of the actuator spindle in motor steps (measured from the left reference position). In the operation or in manual mode this limit will never be exceeded |                 |                 |
| <b>Range:</b>     | 0  | to              | 10'000          |
| <b>Increment:</b> | 1  |                 |                 |
|                   |  | <b>Default:</b> | Factory setting |
|                   |  | <b>Unit:</b>    | [Step]          |

### Drive Direction [DriveDir]

**Purpose:** This parameter determines the guiding orientation of the controller. Usually stepper motors turn clockwise. This setting changes the turning direction of the motor. There are two other possibilities to change the guiding direction:

The user can choose between two settings

**Setting:** [Standard]

**Purpose:** [Standard] is chosen when standard motors and standard frames are used.

**Setting:** [Invers]

**Purpose:** [Invers] is chosen when motors are used that turn anticlockwise.

## 7.3 Reset to Default Parameter Set

Factory settings of your BKS015 web guide controller can be re-established by pressing a combination of two keys.

Hold the two keys  +  while powering -up the controller

## 8 Parameter Setting via a PC

The BKS015 web guide controller can be embedded in an Ethernet network and the parameter setting can be done over this network by means of a web browser (Internet Explorer 7). The devices have a static IP-address that can be set over the user interface. The IP-address is not automatically received over DHCP.

The parameter setting can also be carried out with a desktop- or laptop computer via a peer-to-peer connection (see chapter 8.2)

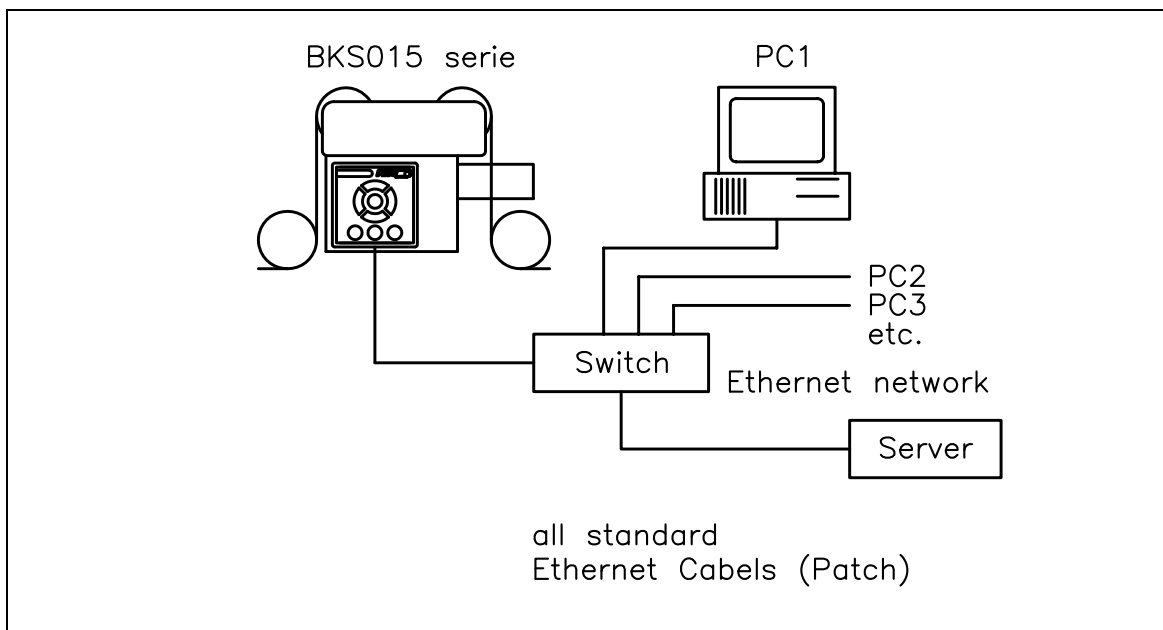

Fig. 13: BKS015 configuration in a LAN (Local Area Network).

K015009e



### Note

*Fig. 14 and 15 show the peer-to-peer connection between PC und BKS015. Use for this configuration a cross-over-cable and not the standard patch Ethernet cable.*

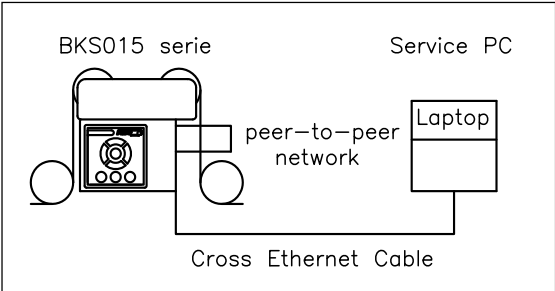

**Fig. 14:** Correct connection with cross-over-cable.  
K015010e

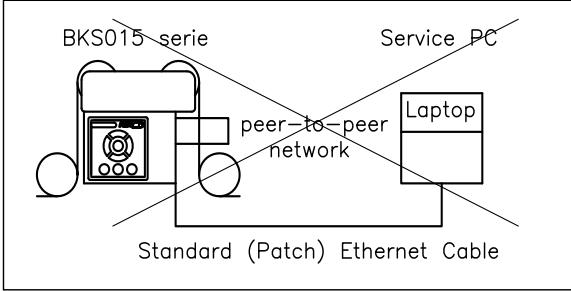
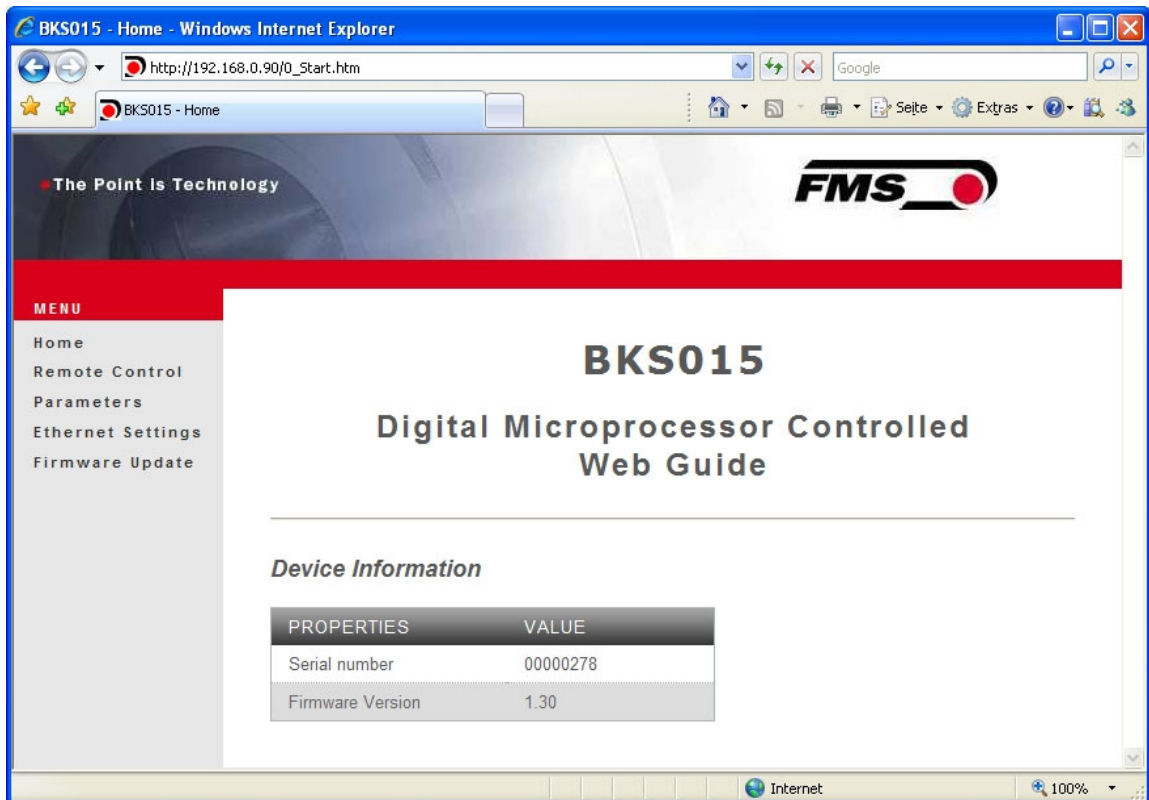

**Fig 15:** Connection with wrong cable  
K05011e

## 8.1 Parameterization in a Network via Web Browser

Before the parameterization of the BKS015 is done it must be certain that the BKS015 uses an IP address in a static block. For the integration of a BKS15 web guide controller in your Ethernet network please contact your IT system administrator.

Once the BKS015 was integrated in the network you can address the device e.g. with <http://192.168.0.90> . After establishing the link, the screen **Fig.16** will open up.



**Fig. 16:** Serial number and device information  
Home.jpg

With the menu on the left side of the screen you can navigate through the web page.

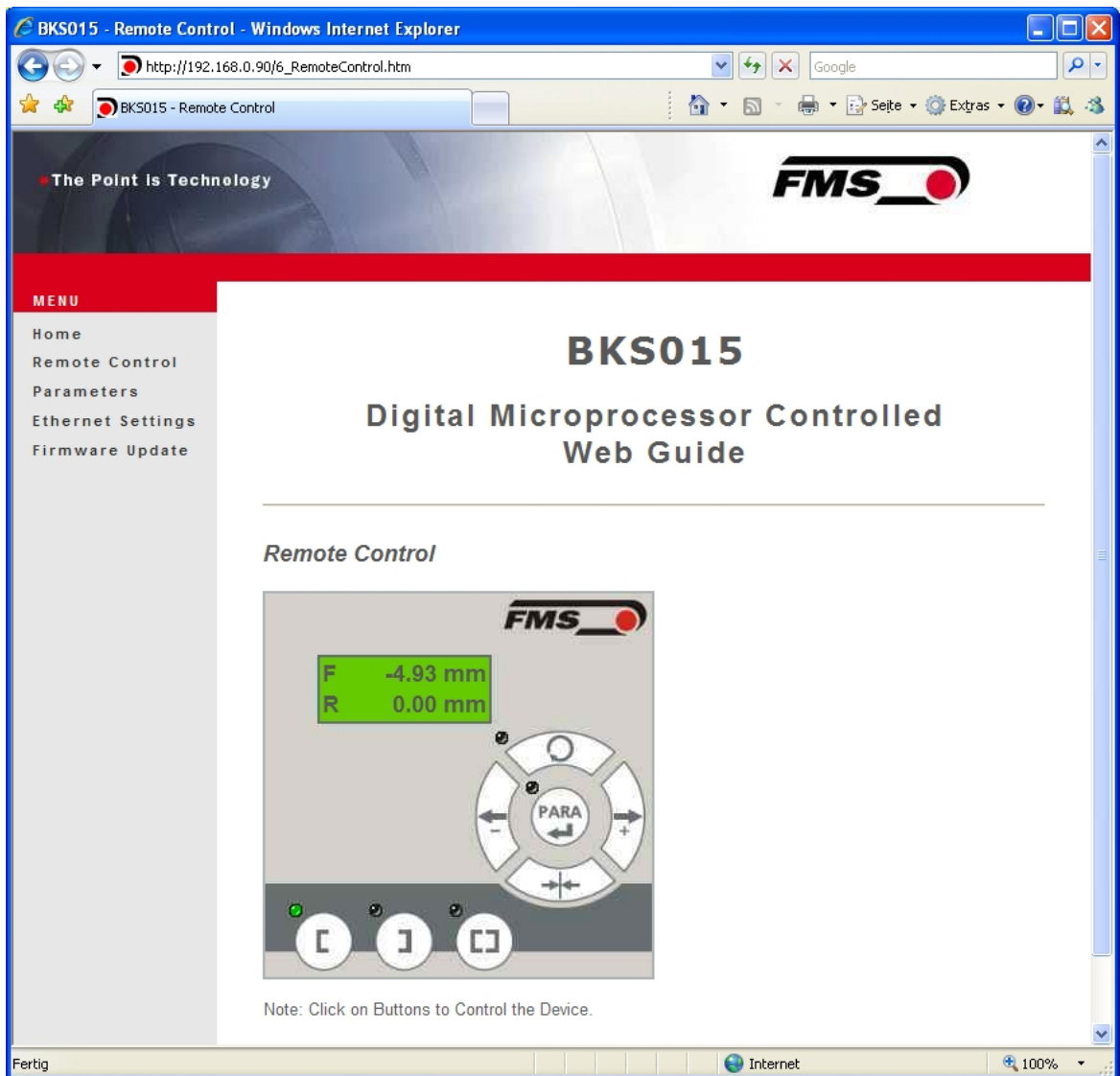

Fig. 17: Front panel for remote control purposes

Remote Control

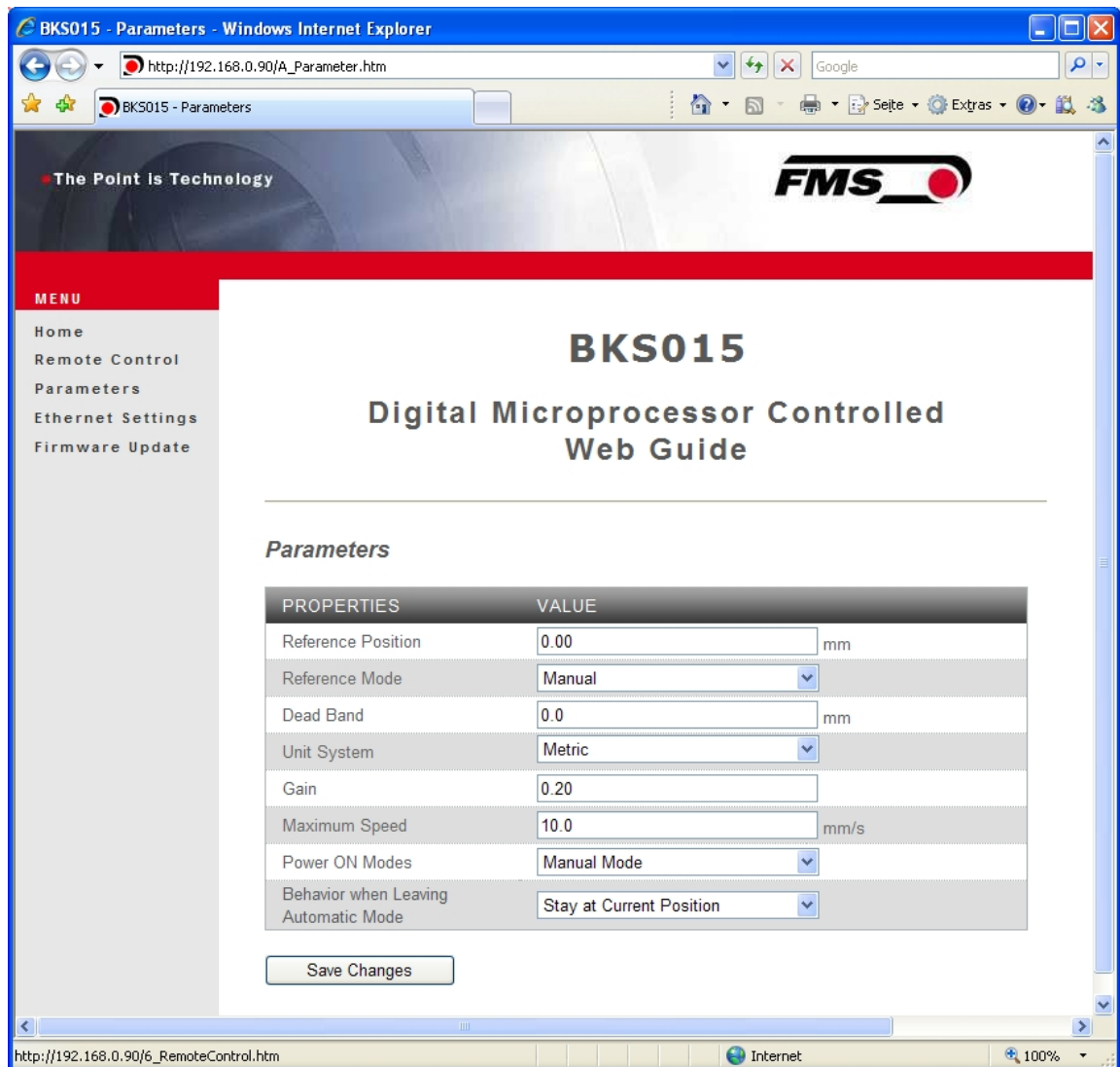

Fig. 18: Parameter list. Parameters can be changed

Parameters

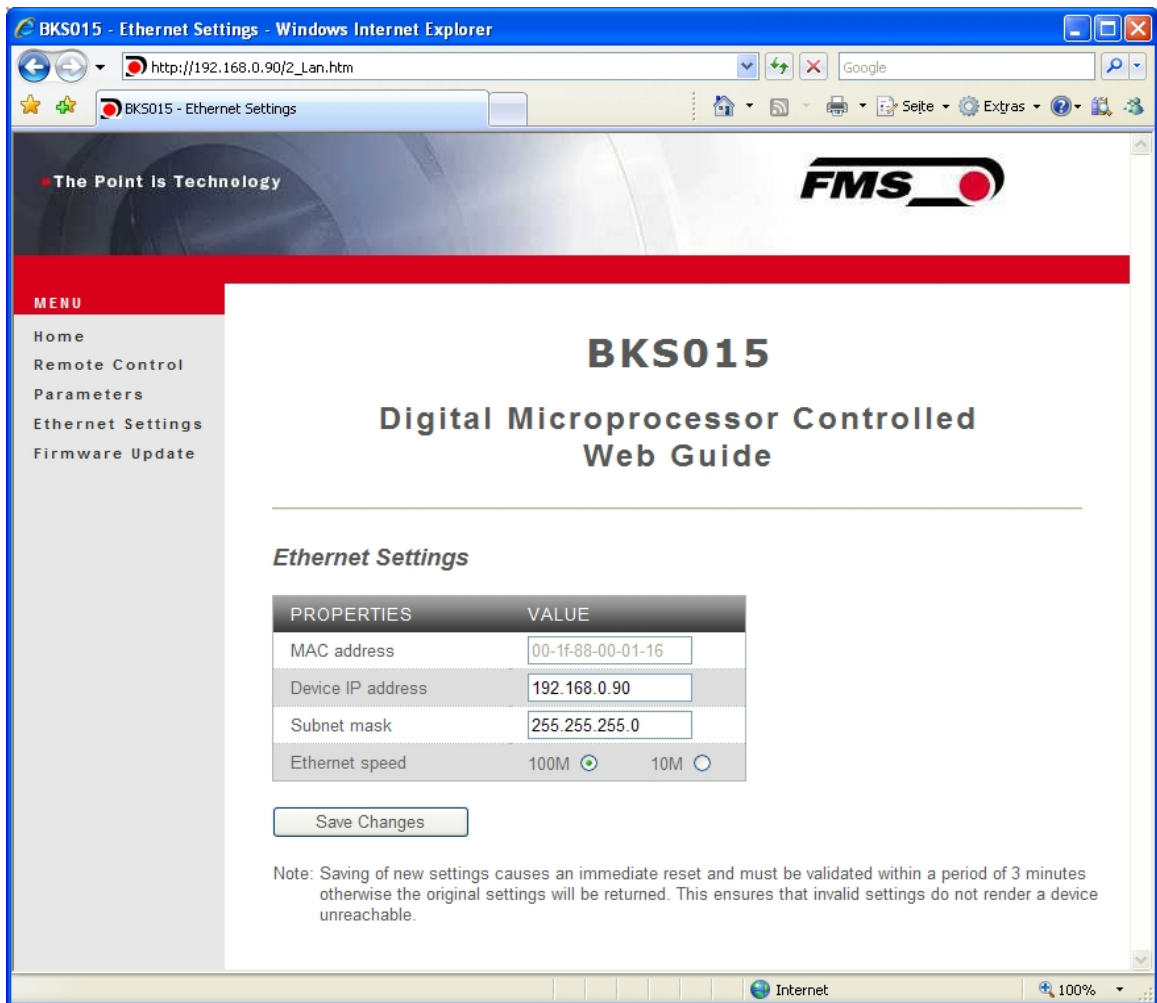

Fig. 19: Ethernet settings and device addresses  
Ethernet Settings

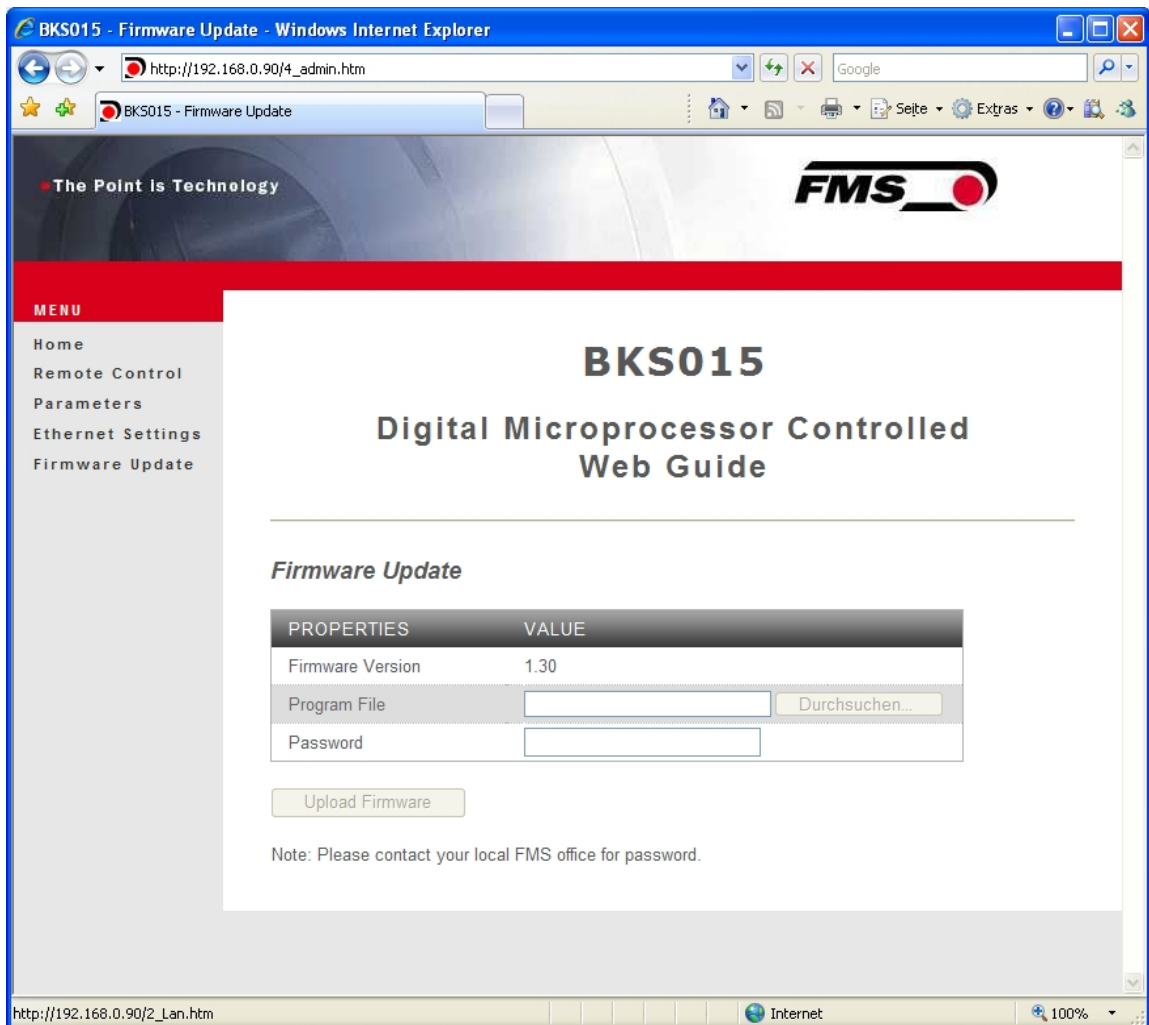

Fig. 20: Firmware update

Firmware Updates

## 8.2 Parameterization via a PC (peer-to-peer connection)

This chapter describes the procedure for setting up a desktop or laptop computer to communicate with FMS BKS015 web guide controller.

Before connecting the FMS BKS015 controller with a “cross-over-cable” directly to a PC, the computer must be configured with a “static” IP address that lets it recognize the BKS015. If the BKS015 controller is connected to a network by using e.g. a switch, the following procedure is not necessary. To establish the connection between your PC and the BKS015 follow the steps below.

## Setup in Microsoft Windows XP:

1. Click on the Start button (lower left-hand corner of the screen)
2. Click on Control Panel
3. Double click on Local Area Network
4. Right click on the network adapter that is used for the connection.
5. Click on Properties on the pop up menu, the following dialog box “Local Area Connection Properties” will appear.

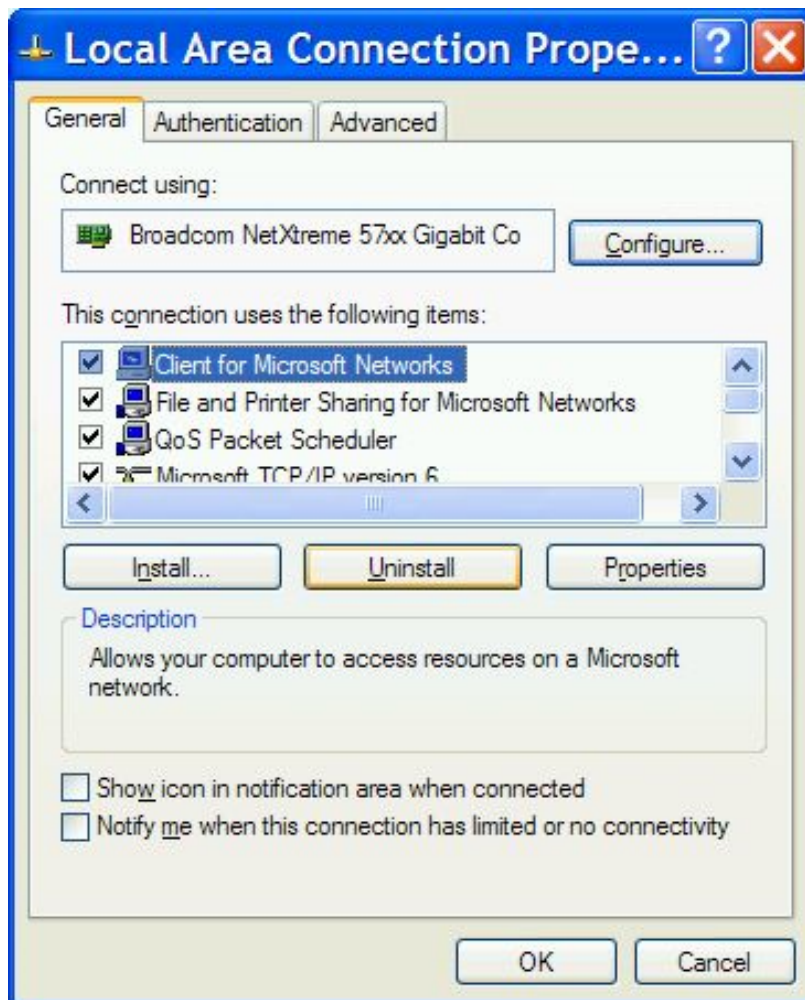

In the box “This connection uses the following items:”, scroll down to “Internet Protocol (TCP/IP)”. Select the “Internet Protocol (TCP/IP)” and click “Properties” button.

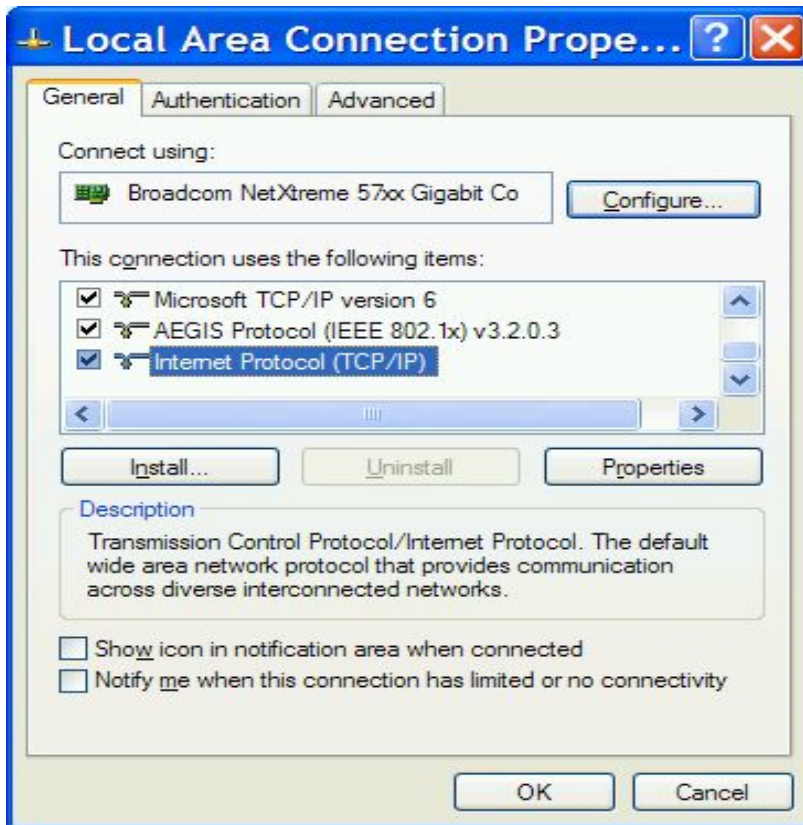

The following dialog box will appear. Make sure the “General” tab is selected.

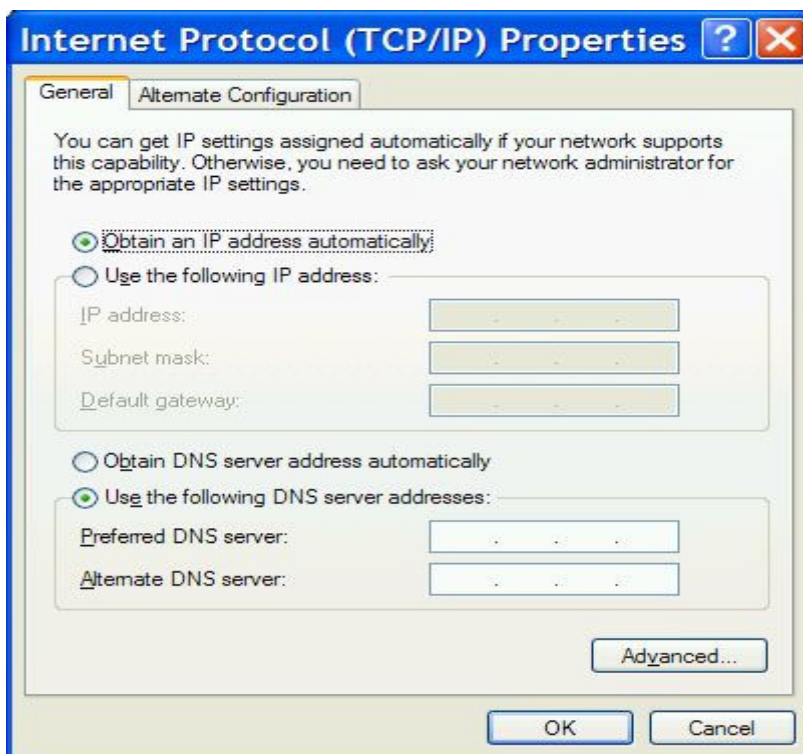

Select the radio button “Use the following IP address:”

In the IP address box enter the IP address for the computer that could be 192.168.0.1.

In the Subnet mask, enter 255 255 255 000, as shown below.

Notice that the “000” in both boxes will change automatically to “0”.

The dialog box will change to look like the following:

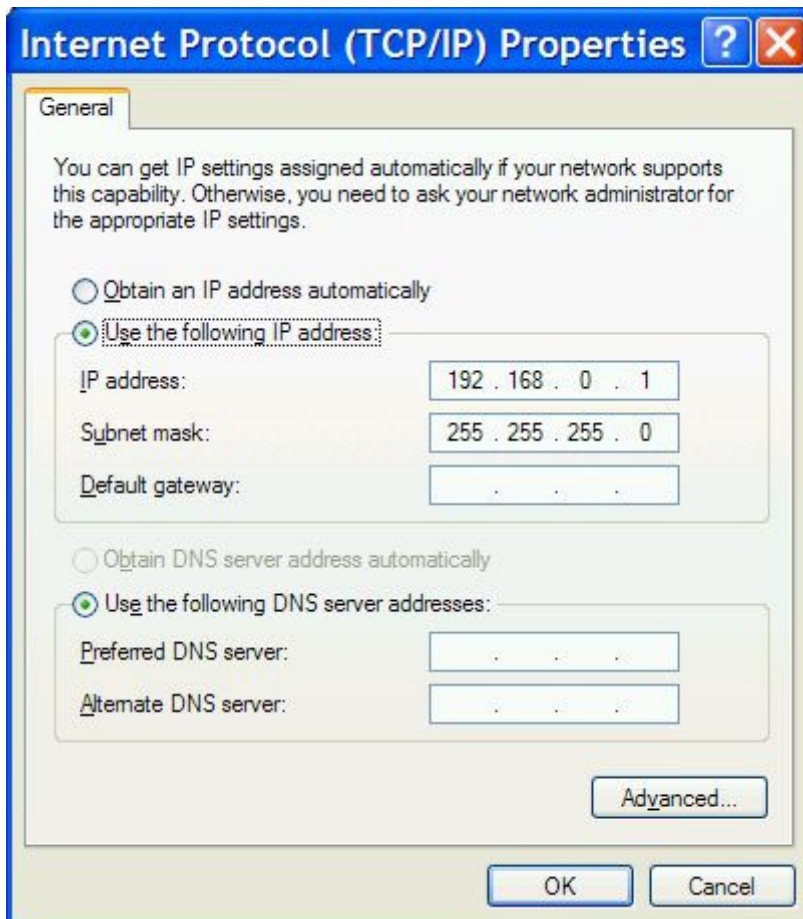

Click the “OK” button. The following dialog box will appear again:

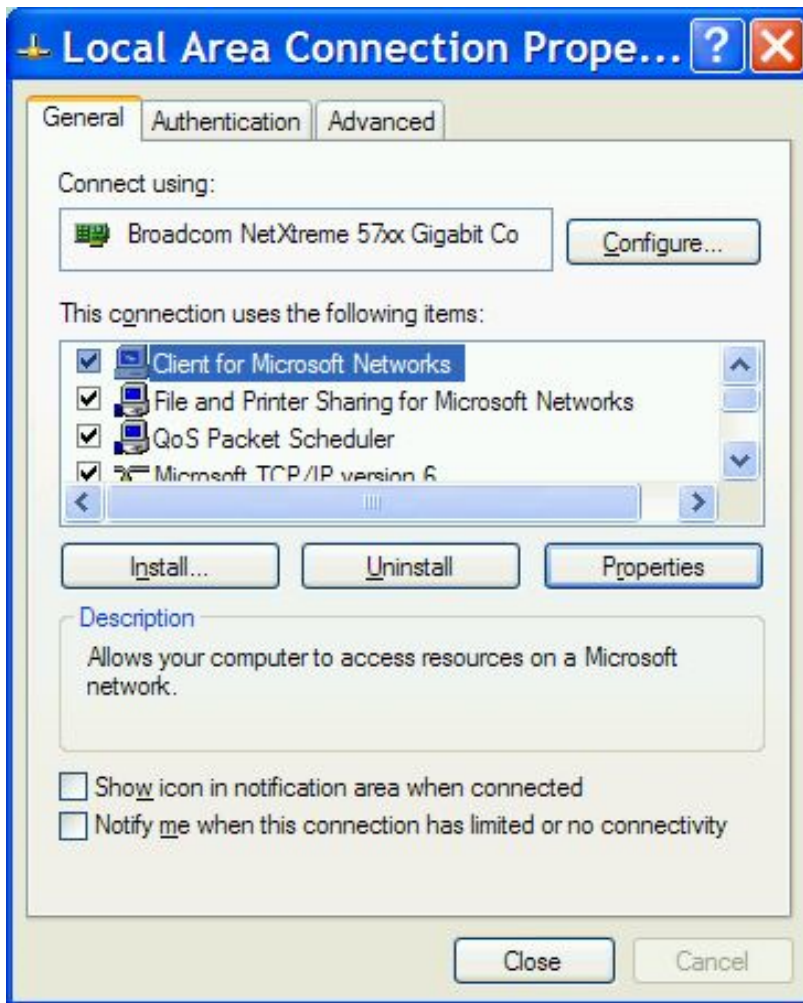

Click on the “Close” button.  
 Close the “Network Connection” window  
 Close “Control Panel”

The computer is now ready to communicate with the BKS015 controller:

1. Connect the “cross over cable” to both the BKS015 and to the appropriate port on the desktop or laptop computer (see **Fig. 13** and **14**).
2. Open Microsoft Internet Explorer or Mizilla Firefox.
3. The default IP address for the BKS015 is 192.168.000.090 as long as it was not changed over the operating penal. Enter the IP address in the address bar and hit the Enter key. If a different IP address and subnet mask is configured at the BKS015 make sure that the computer is setup appropriate.
4. The screen (**Fig.16**) will open up. Continue then with the procedure described in 8.1 “Parametrization in a Network via a Web Browser”.

## 9 Dimensions

The BKS015 series is available in three different roller length sizes:

- 100mm
- 200mm

- 250mm

The mechanical dimensions can be seen in the following drawing.

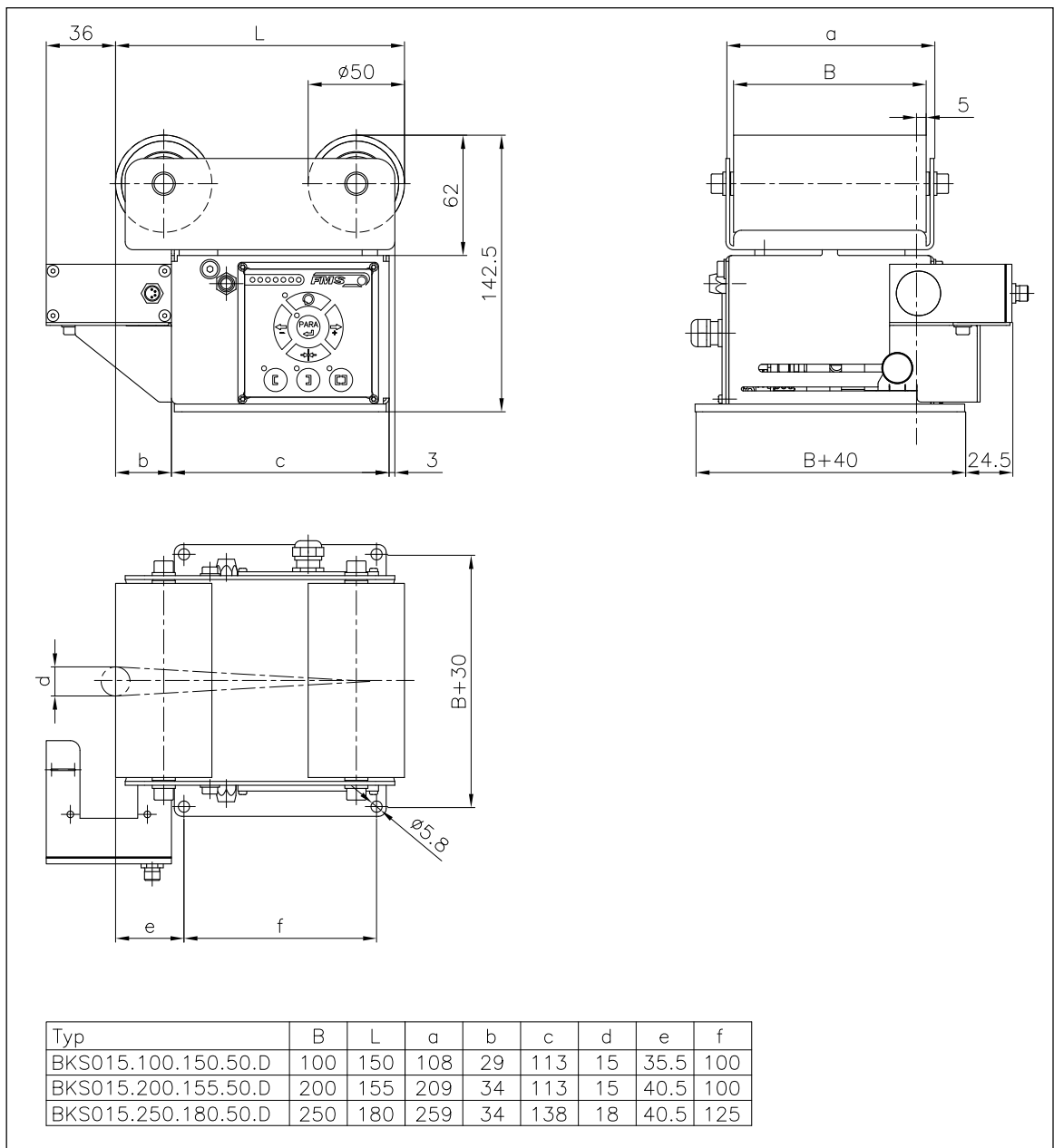

Fig. 21: Outline Drawing BKS015

K015002

## 10 Trouble Shooting

| Error  | Cause  | Corrective action   |
|--|--|---|
| <b>Edge outside detection band</b>                       | Edge has moved outside the sensor detection band | Adjust sensor more accurately to the web edge;<br>Adjust reference position less during automatic operation |
| <b>BKS guides web edge immediately out of the sensor</b> | Sensor is mounted on the wrong side              | Mount sensor to the correct side (right sensor for „Edge right“, etc.)                                      |
|  | Sensor is connected to the wrong socket          | Connect sensor plug to the correct socket (left plug to left socket, etc.)                                  |
| <b>Steering frame does not move</b>                      | No signal; sensor not correctly connected        | Connect sensor correctly according to screw terminal arrangement and installation guide                     |
|  | No signal; cable interruption                    | Replace cable or send sensor to FMS   |
|  | No signal; sensor defect                         | Send sensor to FMS; use other sensor  |
| <b>No response of the interface</b>                      | Wiring not correct                               | Check wiring  |
| <b>LED-row shows nothing, frame doesn't react</b>        | Fuse blown                                       | Replace Fuse on power supply board  |
|  | Power supply defect                              | Check or correct power supply installation  |
|  | Electronic control unit defect                   | Contact FMS customer service  |
| <b>Frame moves abrupt to one of the end positions</b>    | Stepper motor driver defective                   | Exchange actuator of the frame.<br>Contact FMS service department for spare parts and installation guide.   |

## 11 Technical Specification

|                         |  |
|-------------------------|--|
| Cycle time              | 1ms  |
| Drive of steering frame | Stepper motor. Power amplifier 24V integrated in housing |
| Dead band               | 0...2mm, adjustable in 0.1mm steps                       |
| Position reference      | ±5mm, adjustable in 0.1mm steps                          |
| Control modes           | edge left / edge right / center guiding                  |
| Interface               | Web browser Ethernet Explorer 7 or higher                |
| Operation               | 3 keys and 5-key wind rose pad                           |
| Analogue inputs         | 2 inputs 0...10V (for sensors)                           |
| Supply voltage          | 24 (18 to 36) VDC  |
| Temperature range       | -10 ... 60°C (14 to 140°F)                               |
| Protection class        | IP 30  |



**FMS Force Measuring  
Systems AG**  
Aspstrasse 6  
8154 Oberglatt (Switzerland)  
Tel. 0041 1 852 80 80  
Fax 0041 1 850 60 06  
info@fms-technology.com  
www.fms-technology.com

**FMS USA, Inc.**  
2155 Stonington Avenue  
Suite 119  
Hoffman Estates,, IL 60169  
(USA)  
Tel. +1 847 519 4400  
Fax +1 847 519 4401  
fmsusa@fms-  
technology.com

**FMS (UK)**  
Aspstrasse 6  
8154 Oberglatt (Switzerland)  
Tel. +44 (0)1767 221 303  
fmsuk@fms-technology.com

**FMS (Italy)**  
Aspstrasse 6  
8154 Oberglatt (Switzerland)  
Tel. +39 02 39487035  
fmsit@fms-technology.com