



## AX320 / AX322

Process indicators for standard analog signals with 2 presets / relays and 2 control inputs

### Product features:

- Two identical models, but with a different power supply range
- Analog input 0 ... +/-10 V (or 2 – 10 V) and 0 – 20 mA (or 4 – 20 mA)
- Two relay outputs for limit monitoring (dry changeover contacts)
- Two digital multi-function inputs with programmable control function
- Useful supplementary functions like Digital Filter, Linearization, Totalizer etc.
- 6 digit 14-segment display (14 mm / 0.55" size) for readout and menu dialogues

### Available devices:

- **AX320:** Power supply 10 – 30 VDC
- **AX322:** Power supply 90 – 240 VAC and auxiliary output 24 VDC

Version:	Description
AX32001a/hk/05_2011	First edition
AX32001b/tj/nw/02_2014	Small changes
Ax320_01c_oi/Apr-16/ag	Design and "Safety Instructions" updated

Legal notices:
All contents included in this manual are protected by the terms of use and copyrights of motrona GmbH. Any reproduction, modification, usage or publication in other electronic and printed media as well as in the internet requires prior written authorization by motrona GmbH.

## Table of Contents

<b>1. Safety Instructions and Responsibility .....</b>	<b>3</b>
1.1 General Safety Instructions .....	3
1.2 Use according to the intended purpose.....	3
1.3 Installation.....	4
1.4 Cleaning, Maintenance and Service Notes .....	4
<b>2. Short Form Description.....</b>	<b>5</b>
<b>3. Display and Operating Elements .....</b>	<b>6</b>
3.1 Overview.....	6
3.2 Special Key Functions .....	6
<b>4. Block Diagram and Terminal Assignments .....</b>	<b>7</b>
<b>5. Operating Concept (Mode of Operation).....</b>	<b>8</b>
<b>6. Programming.....</b>	<b>9</b>
6.1 How to Enter the Menu / Select a Function Group / Quit the Menu: .....	9
6.2 How to Select Functions / Set Parameters / Accept Settings .....	10
<b>7. Function Groups .....</b>	<b>11</b>
7.1 Help Texts (running text).....	11
7.2 Signal Inputs.....	11
7.3 User Linearization.....	12
7.4 Multifunction Key (MP-Key) and Multifunction inputs (MP-INP).....	15
7.5 Totalizer Function .....	18
7.6 Limit Value (Alarm) Monitoring.....	20
7.7 Monitoring of the Measuring Circuit.....	25
<b>8. Technical Specifications .....</b>	<b>26</b>
<b>9. Dimensional Drawings .....</b>	<b>28</b>
<b>10. Help Texts.....</b>	<b>29</b>

# 1. Safety Instructions and Responsibility

## 1.1 General Safety Instructions

This operation manual is a significant component of the unit and includes important rules and hints about the installation, function and usage. Non-observance can result in damage and/or impairment of the functions to the unit or the machine or even in injury to persons using the equipment!

**Please read the following instructions carefully before operating the device and observe all safety and warning instructions! Keep the manual for later use.**

A pertinent qualification of the respective staff is a fundamental requirement in order to use these manual. The unit must be installed, configured, commissioned and serviced by a qualified electrician.

**Liability exclusion:** The manufacturer is not liable for personal injury and/or damage to property and for consequential damage, due to incorrect handling, installation, operation and maintaining. Further claims, due to errors in the operation manual as well as misinterpretations are excluded from liability. In addition the manufacturer reserves the right to modify the hardware, software or operation manual at any time and without prior notice. Therefore, there might be minor differences between the unit and the descriptions in operation manual.

The raiser respectively positioner is exclusively responsible for the safety of the system and equipment where the unit will be integrated.

During installation, operation or maintenance all general and also all country- and application-specific safety rules and standards must be observed.

If the device is used in processes, where a failure or faulty operation could damage the system or injure persons, appropriate precautions to avoid such consequences must be taken.

## 1.2 Use according to the intended purpose

The unit is intended exclusively for use in industrial machines, constructions and systems. Non-conforming usage does not correspond to the provisions and lies within the sole responsibility of the user. The manufacturer is not liable for damages which has arisen through unsuitable and improper use.

Please note that device may only be installed in proper form and used in a technically perfect condition in accordance to the "Technical Specifications". The device is not suitable for operation in explosion-proof areas or areas which are excluded by the EN 61010-1 standard.

## 1.3 Installation

The device is only allowed to be installed and operated within the permissible temperature range. Please ensure an adequate ventilation and avoid all direct contact between the device and hot or aggressive gases and liquids.

Before installation or maintenance, the unit must be disconnected from all voltage-sources. Further it must be ensured that no danger can arise by touching the disconnected voltage-sources.

Devices which are supplied by AC-voltages, must be connected exclusively by switches, respectively circuit-breakers with the low voltage network. The switch or circuit-breaker must be placed as near as possible to the device and further indicated as separator.

Incoming as well as outgoing wires and wires for extra low voltages (ELV) must be separated from dangerous electrical cables (SELV circuits) by using a double resp. increased isolation.

All selected wires and isolations must be conform to the provided voltage- and temperature-ranges. Further all country- and application-specific standards, which are relevant for structure, form and quality of the wires, must be ensured. Indications about the permissible wire cross-sections for wiring are described in the "Technical Specifications" chapter.

Before first start-up it must be ensured that all connections and wires are firmly seated and secured in the screw terminals. All (inclusively unused) terminals must be fastened by turning the relevant screws clockwise up to the stop.

Overvoltages at the connections must be limited to values in accordance to the overvoltage category II.

For placement, wiring, environmental conditions as well as shielding and earthing/grounding of the supply lines the general standards of industrial automation industry and the specific shielding instructions of the manufacturer are valid. Please find all respective hints and rules on [www.motrona.com/download.html](http://www.motrona.com/download.html) --> "[General EMC Rules for Wiring, Screening and Earthing]".

## 1.4 Cleaning, Maintenance and Service Notes

To clean the front of the unit please use only a slightly damp (not wet!), soft cloth. For the rear no cleaning is necessary. For an unscheduled, individual cleaning of the rear the maintenance staff or assembler is self-responsible.

During normal operation no maintenance is necessary. In case of unexpected problems, failures or malfunctions the device must be shipped for back to the manufacturer for checking, adjustment and reparation (if necessary). Unauthorized opening and repairing can have negative effects or failures to the protection-measures of the unit.

## 2. Short Form Description

The units of series AX320 and AX322 have been designed for digital readout and monitoring of analog measuring values with industrial applications of automation.

- Model AX320 provides a power supply input of 24 VDC.
- Model AX322 provides a power supply input of 90 – 240 VAC and offers an additional auxiliary output with 24 VDC / 30 mA for sensor supply purpose.





All further properties of these two models are fully identical.

The subsequent list shows a summary of technical specifications of AX320 / AX322 units::







- 6-digit 14-segment LED display, 14 mm, for displaying measured values and dialogs
- Running text can be switched on as Help Text
- Language for the Help Text selectable as English or German
- Signal input for 0 – 10 V, 2 – 10 V,  $\pm 10$  V, 0 – 20 mA and 4 – 20 mA
- Sampling rate 10 readings per second
- Digital filter (1st order) for smoothing display fluctuations with unstable input signals
- Customized linearization
- MIN/MAX memory function
- Totalizer function
- 2 Relay outputs (changeover contacts) for limit monitoring
- Start delay for relay outputs after Power ON
- Versions for supply voltage 10 ... 30 V DC and 90 ... 260 V AC
- Auxiliary power supply 15 V DC / 25 mA
- Additional aux. power output 24 V / 30 mA with AC supply
- Programmable via the front keys
- Multifunction key and two multifunction inputs, function programmable

# 3. Display and Operating Elements

## 3.1 Overview

<p><b>(1) Display</b>          - 14 segment display, 6-digit, red          - Height of figures 14 mm</p>	
<p><b>(2) Status display</b> ( 2 LED annunciators, red)          - Switching status of Alarm 1 and Alarm 2          - Indication Function Group or Function</p>	
<p><b>(3) MP-Key and Programming Keys</b></p>	
<p> - Multifunction key (MP-Key)</p>	
<p> - Return from Function Group          - Return from Function</p>	
<p> - Select previous Function Group          - Select previous Function          - Decrement parameter value</p>	
<p> - Select next Function Group          - Select next Function          - Increment parameter value</p>	
<p> - Enter a Function Group          - Enter a Function          - Accept the new setting</p>	
<p><b>(4) Space for unit overlay</b></p>	

## 3.2 Special Key Functions

To enter the Programming Menu:	 +  [ $> 3 \text{ sec}$ ]
To display Device Type and Software Version:	 +  +  [ $> 5 \text{ sec}$ ]
To restore factory default settings:	 +  [ $> 3 \text{ sec}$ ]

# 4. Block Diagram and Terminal Assignments

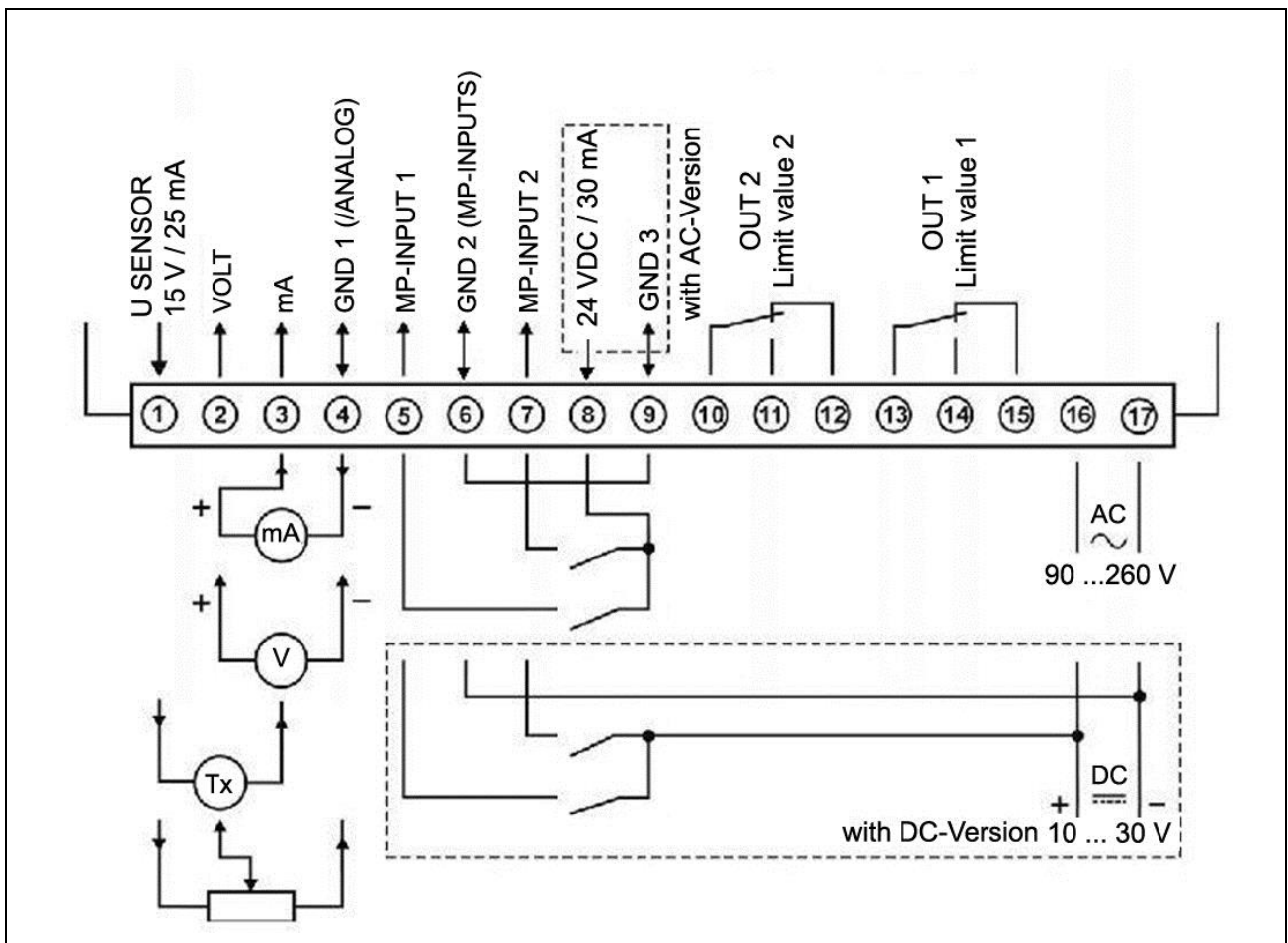
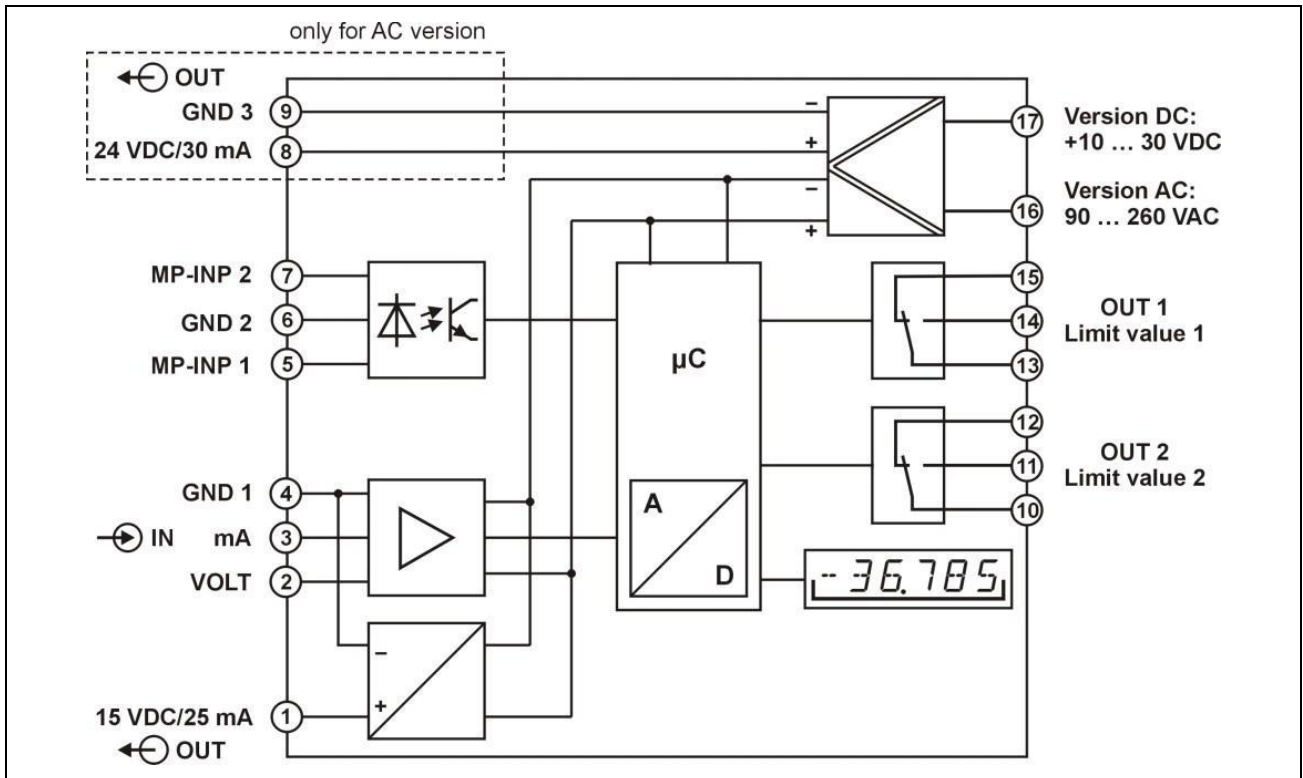

# 5. Operating Concept (Mode of Operation)

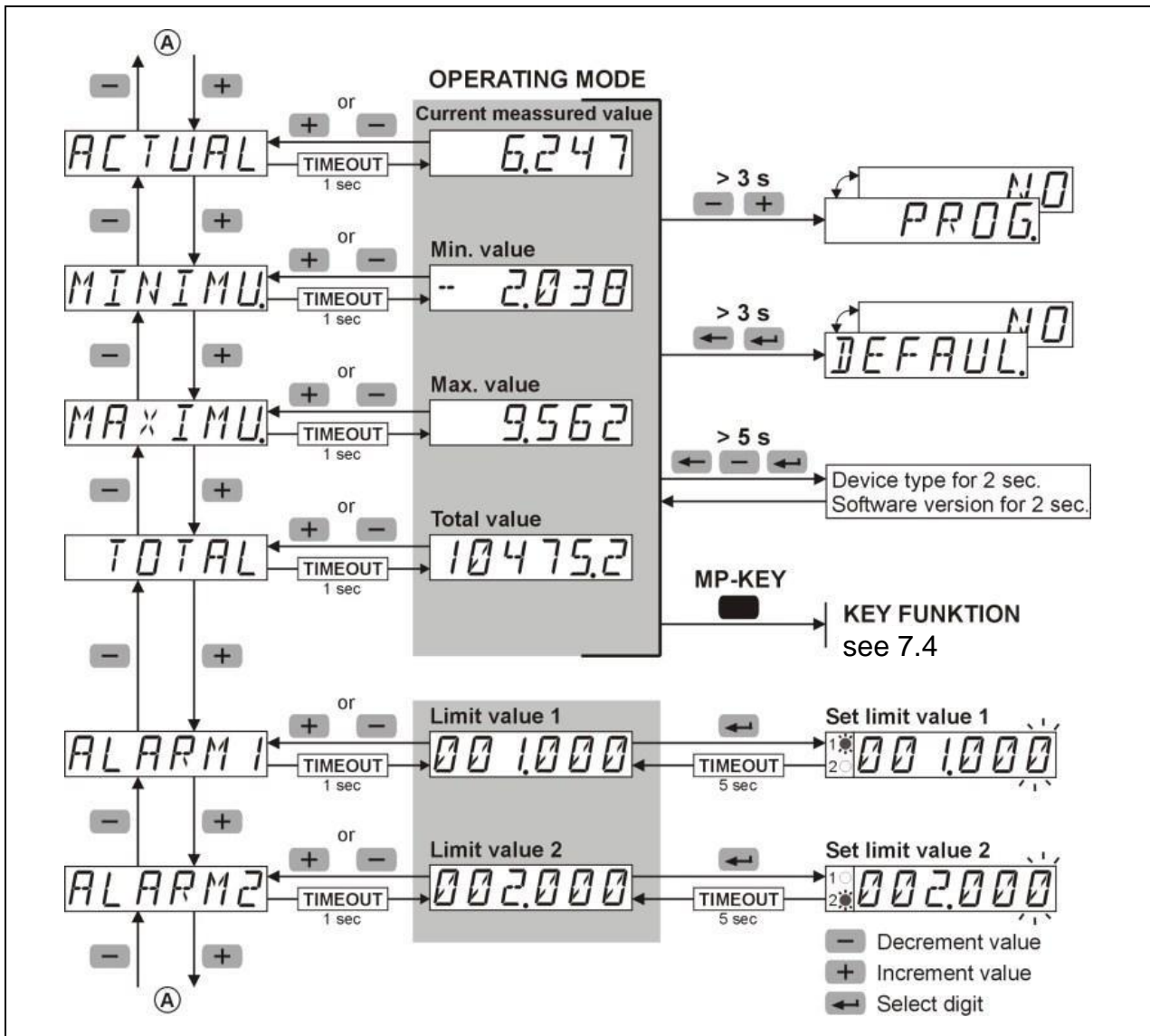

# 6. Programming



- To enter the programming menu, press **- + +** [**> 3 sec**]
- During programming the relays are inactive (not energized)
- When quitting the programming menu via SAVE, the minimum and maximum values and the totalizer value are all cleared

## 6.1 How to Enter the Menu / Select a Function Group / Quit the Menu:

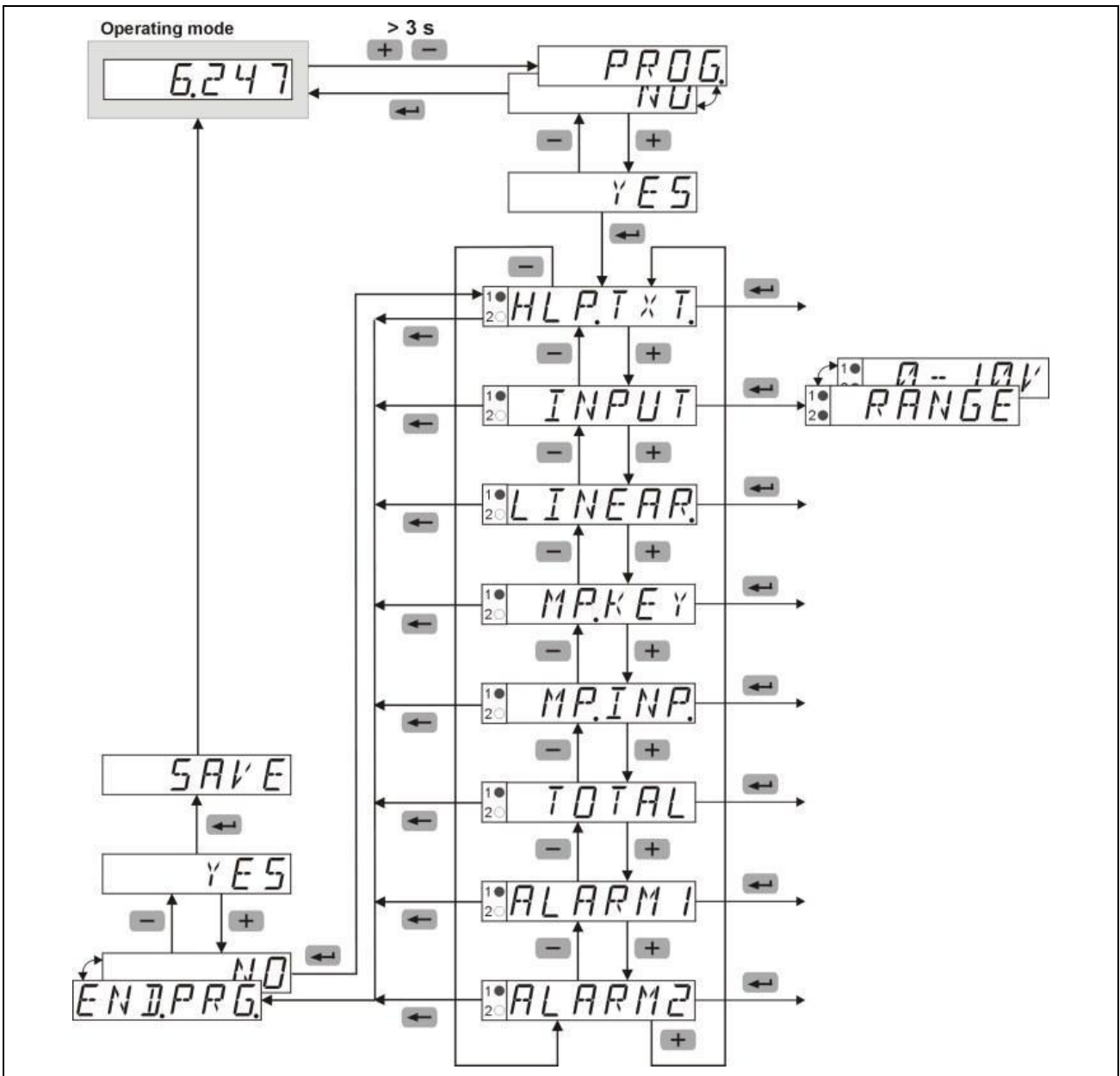

## 6.2 How to Select Functions / Set Parameters / Accept Settings

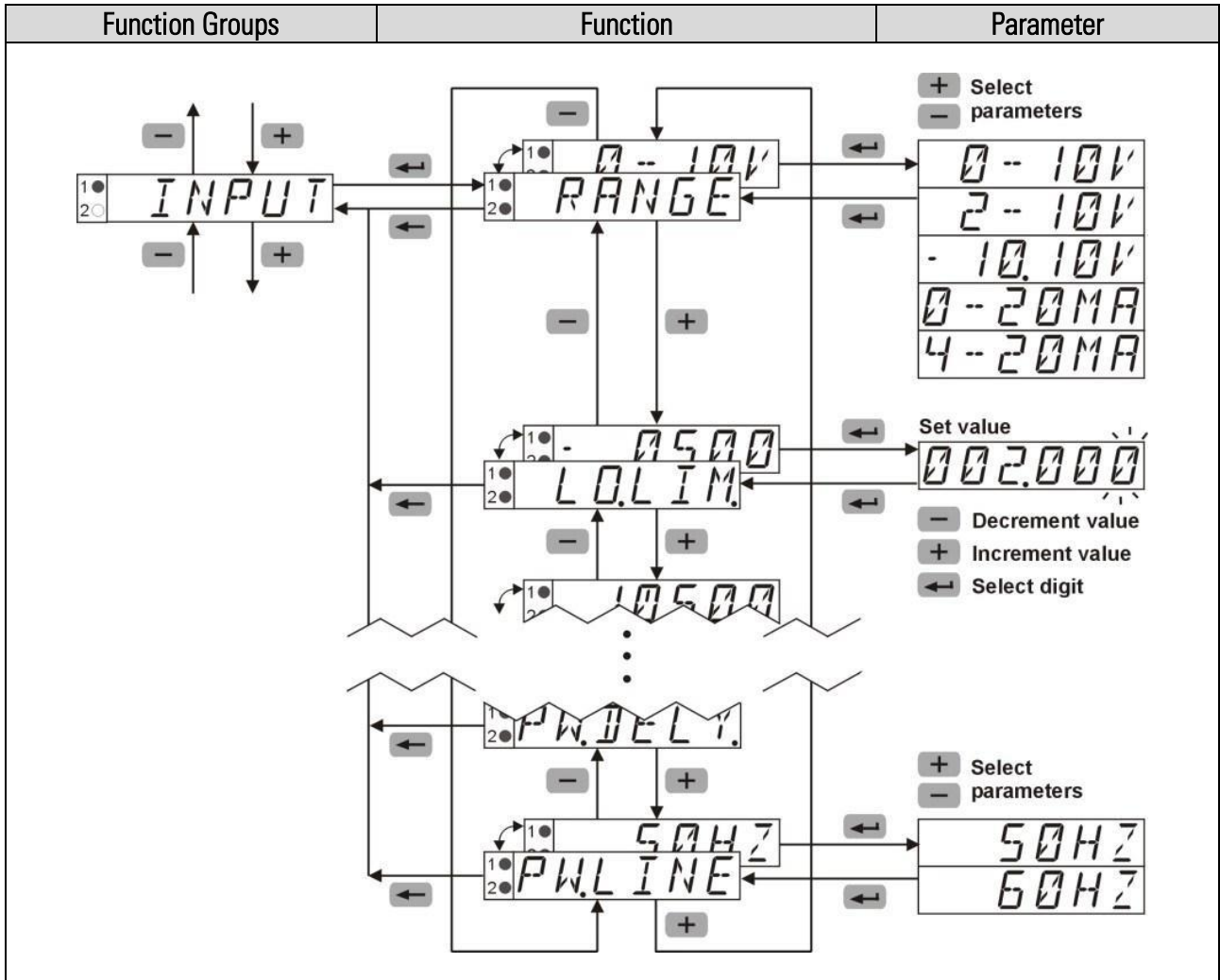

# 7. Function Groups



In the subsequent chapters the Factory Default Settings are highlighted by grey color.

## 7.1 Help Texts (running text)

<i>HLP.TXT</i>	Help Text Menu
<i>HLP.TXT</i>	Select Help Text
<i>ON</i>	ON: running texts that have started can be aborted by any programming key
<i>OFF</i>	OFF
<i>SL.LANG</i>	Select Language for Help Texts
<i>EN</i>	English
<i>DE</i>	Deutsch (German)

## 7.2 Signal Inputs

<i>INPUT</i>	Menu Input Signal
<i>RANGE</i>	Select measuring range
<i>0-10V</i>	Range 0 ... 10 V
<i>2-10V</i>	Range 2 ... 10 V
<i>-10,10V</i>	Range -10 ... +10 V
<i>0-20mA</i>	Range 0 ... 20 mA
<i>4-20mA</i>	Range 4 ... 20 mA
<i>LO.LIM</i>	Select lower measuring range limit
<i>-0.500</i>	Setting range depends on measuring range [V / mA]
<i>HILIM</i>	Select upper measuring range limit
<i>10.500</i>	Setting range depends on measuring range [V / mA]
<i>DP</i>	Select Decimal Point (visual function only)
<i>0.000</i>	0 - 0.0 - 0.00 - 0.000 - 0.0000
<i>INP.LO</i>	Select input low value
<i>0.000</i>	Setting range depends on measuring range [V / mA]
<i>DISP.LO</i>	Select low display value for INP.LO.
<i>0.000</i>	Setting range -199999 ... +999999 and decimal point

INP.HI.	Select input high value
10.000	Setting range depends on measuring range [V / mA]
DISP.HI.	Select high display value for INP.HI.
10.000	Setting range -199999 ... +999999 and decimal point
FILTER	Select input filter: (number of measuring cycles for floating average calculation)
1	Setting range 1 ... 99 [cycles], with setting 1 the filter is turned off
PW.DEL.Y.	Select start delay after power on (limit monitoring is processed only after the programmed time has expired)
0.0	Setting range 0.0 ... 99.9 [sec]
PW.FREQ	Select local mains frequency
50HZ	Mains frequency 50 Hz
60HZ	Mains frequency 60 Hz



- The setting range depends on the selected measuring range:
 

0 ... 10 V	=	-0.500 ... 10.500 [V]
2 ... 10 V	=	1.500 ... 10.500 [V]
-10 ... +10 V	=	-10.500 ... +10.500 [V]
0 ... 20 mA	=	-0.500 ... 21.000 [mA]
4 ... 20 mA	=	3.000 ... 21.000 [mA]
- The functions LO.LIM and HI.LIM will limit the editable range correspondingly.
- The setting of HI.LIM has to be greater than the setting of LO.LIM at any time.

## 7.3 User Linearization

LINEAR.	Menu User-Linearization
LINEAR.	Select User Linearization
NO	Linearization OFF
YES	Linearization ONF
NUM.PNT.	Select number of interpolation points
3	Setting range 3 ... 12 points
INP.LO.	Select input low value
0.000	Setting range depends on measuring range [V / mA]
DISP.LO.	Select display low value for INP.LO.
0.000	Setting range -199999 ... +999999 and decimal point.

INP.01	Select input value 1
0.000	Setting range depends on measuring range [V / mA]
DISP.01	Select display value for INP.01.
0.000	Setting range -199999 ... +999999 and decimal point.
INP.10	Select input value 10
0.000	Setting range depends on measuring range [V / mA]
DISP.10	Select display value for INP.10.
0.000	Setting range -199999 ... +999999 and decimal point.
INP.HI	Select input high value
10.000	Setting range depends on measuring range [V / mA]
DISP.HI	Select display value for INP.HI.
10.000	Setting range -199999 ... +999999 and decimal point.



- A maximum of 12 linearization points is possible.
- An input value INP must be entered for each linearization point (LP) (input of the sensor value from the analog input in physical units) as well as the corresponding display value DISP for this sensor value.
- The linearization points (LP) may be entered in any order. They are then sorted in the firmware in ascending order for the linearization function.
- Linearization based on a negative slope is possible.
- The setting range depends on the selected measuring range:
 

0 ... 10 V	=	-0.500 ... 10.500 [V]
2 ... 10 V	=	1.500 ... 10.500 [V]
-10 ... +10 V	=	-10.500 ... +10.500 [V]
0 ... 20 mA	=	-0.500 ... 21.000 [mA]
4 ... 20 mA	=	3.000 ... 21.000 [mA]
- The functions LO.LIM and HI.LIM limit the editable range.  
The value for HI.LIM must always be greater than the value for LO.LIM.

### 7.3.1 Example for linear scaling

Example 1: 0 - 10 V = 0 ... 600, Example 2: 4 - 20 mA = 300 - 900, Example 3: 1.0 - 9.0 V = 750 - 400

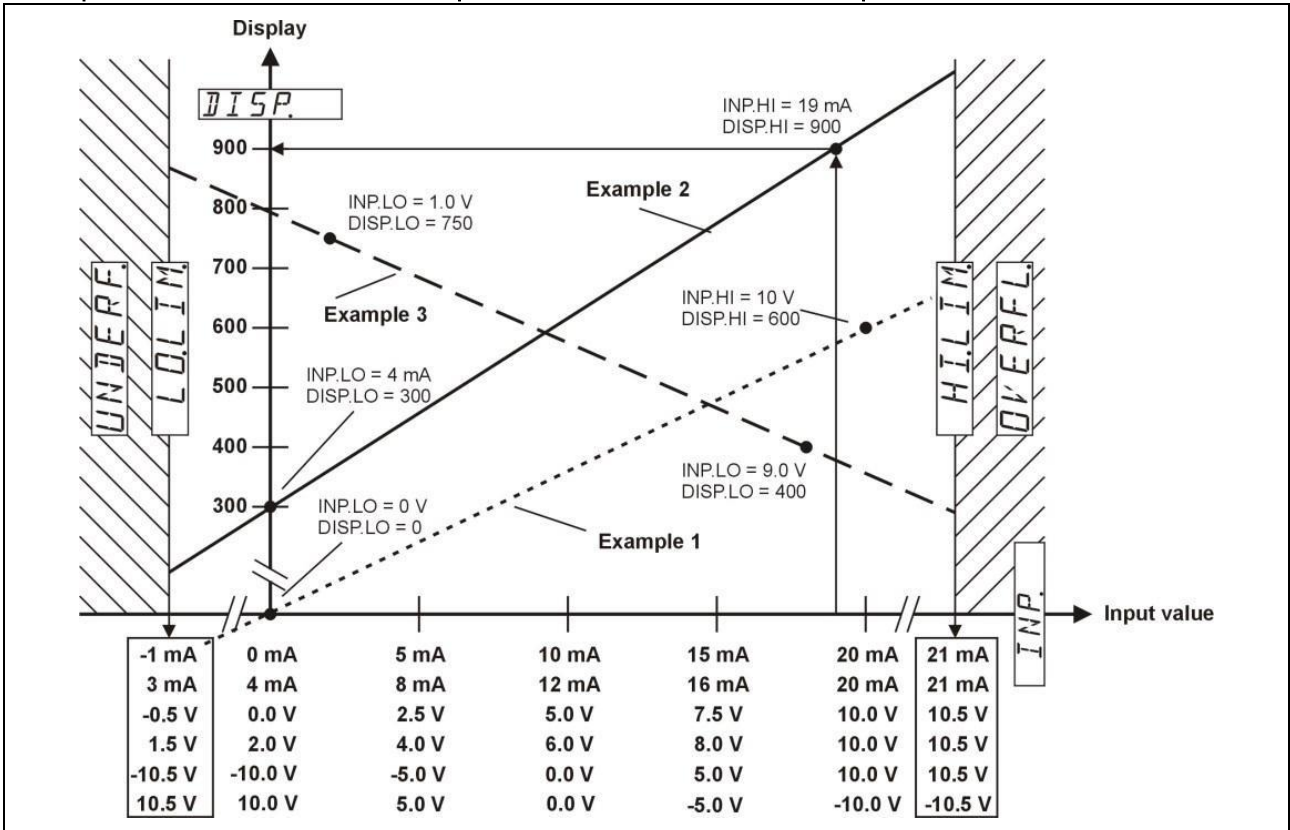

### 7.3.2 Example for non-linear scaling

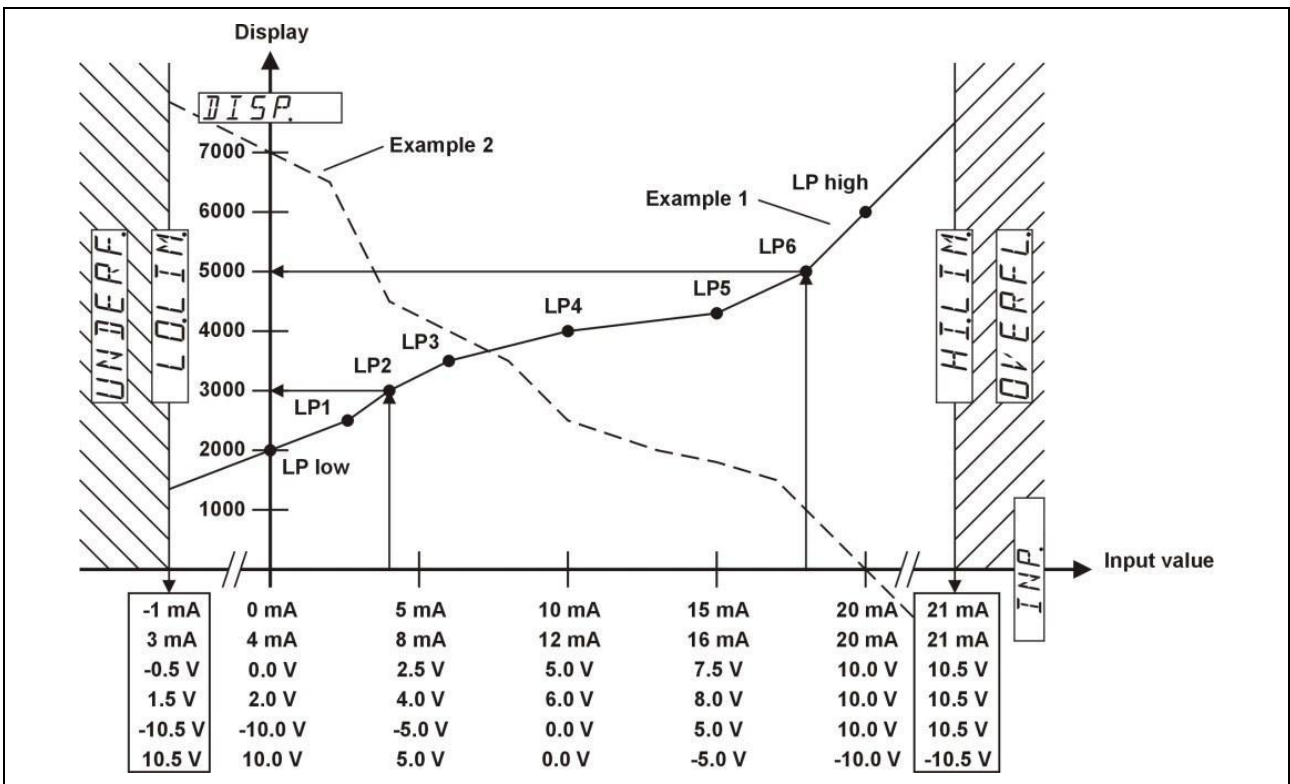

## 7.4 Multifunction Key (MP-Key) and Multifunction inputs (MP-INP)

### Tare

- In the function group MP.KEY, programme the function TARA to ON. In the operating mode select the current measured value (ACTUAL) and briefly press the MP Key.
- In the function group MP.INP, programme the function MP.INP1 or MP.INP2 to TARA. In the operating mode briefly activate the multifunction input 1 or multifunction input 2

### Reset Tare Value

- In the function group MP.KEY, programme the function TARA to ON. In the operating mode select the current measured value (ACTUAL) and press the MP Key >5 sec.
- In the function group MP.INP, programme the function MP.INP1 or MP.INP2 to R.TARA. In the operating mode briefly activate the multifunction input 1 or multifunction input 2.

### Reset MIN value memory

- In the function group MP.KEY, programme the function RES.MIN to ON. In the operating mode select the minimum value memory (MINIMU) and briefly press the MP Key.
- In the function group MP.INP, programme the function MP.INP1 or MP.INP2 to RES.MIN or R.PEAKS. In the operating mode briefly activate the multifunction input 1 or multifunction input 2.

### Reset MAX value memory

- In the function group MP.KEY, programme the function RES.MAX to ON. In the operating mode select the maximum value memory (MAXIMU) and briefly press the MP Key.
- In the function group MP.INP, programme the function MP.INP1 or MP.INP2 to RES.MAX or R.PEAKS. In the operating mode briefly activate the multifunction input 1 or multifunction input 2.

### Reset of relay outputs in Latch mode

- In the function group MP.KEY, programme the function RES.REL to ON. In the operating mode briefly press the MP Key.
- In the function group MP.INP, programme the function MP.INP1 or MP.INP2 to RES.REL. In the operating mode briefly activate the multifunction input 1 or multifunction input 2.

### Reset Totalizer

- In the function group MP.KEY, programme the function RES.TOT to ON. In the operating mode, select the totalizer (TOTAL) and briefly press the MP Key.
- In the function group MP.INP, programme the function MP.INP1 or MP.INP2 to RES.TOT. In the operating mode briefly activate the multifunction input 1 or multifunction input 2

### Display Hold

- In the function group MP.INP, programme the function MP.INP1 or MP.INP2 to DISP.HD.
- In the operating mode, select either the current measured value (ACTUAL) or the totalizer (TOTAL) and activate multifunction input 1 or multifunction input 2.

### Lock-out Limit Value (Alarm) setting

- In the function group MP.INP, programme the function MP.INP1 or MP.INP2 to LOC.ALR.
- In the operating mode, activate multifunction input 1 or multifunction input 2

### Lock-out Programming and Default setting

- In the function group MP.INP, programme the function MP.INP1 or MP.INP2 to LOC.PRG.
- In the operating mode, activate multifunction input 1 or multifunction input 2.

### Lock-out Keypad

- In the function group MP.INP, programme the function MP.INP1 or MP.INP2 to LOC.KEY.
- In the operating mode, activate multifunction input 1 or multifunction input 2.

### 7.4.1 Multifunction Key

<i>MPKEY</i>	Menu Function MP key
<i>TARA</i>	Select function: Reset Tare by MP key (when current measuring value is in display)
<i>OFF</i>	OFF
<i>ON</i>	ON
<i>RESMIN</i>	Select function: Reset MIN value by MP key (when MIN value is in display)
<i>OFF</i>	OFF
<i>ON</i>	ON
<i>RESMAX</i>	Select function: Reset MAX value by MP key (when MAX value is in display)
<i>OFF</i>	OFF
<i>ON</i>	ON
<i>RESREL</i>	Select function: Output Latch Reset by MP key (only if output is in memory mode, ALARMx = LATCH)
<i>OFF</i>	OFF
<i>ON</i>	ON (this setting is possible only if all other settings are set to OFF)
<i>RESTOT</i>	Select function: Reset Totalizer by MP key (when the totalizer value is in display)
<i>OFF</i>	OFF
<i>ON</i>	ON

## 7.4.2 Multifunction Inputs

<i>MP.INP.</i>	<b>Menu Function MP Inputs</b>
<i>MP.INP.1</i>	<b>Select function MP input 1</b>
<i>NO.FUNC.</i>	No function
<i>RES.MIN.</i>	Reset MIN value
<i>RES.MAX.</i>	Reset MAX value
<i>R.PEAKS</i>	Reset MIN and MAX values
<i>RES.REL.</i>	Reset Output-Latch (only if output is in memory mode,ALARMx = LATCH)
<i>DISP.HD.</i>	Hold ('freeze') display
<i>LOCALP.</i>	Lock-out limit value setting
<i>LOC.PRG.</i>	Lock-out programming and default setting
<i>LOCKEY</i>	Lock-out limit value setting, programming, default setting and MP-Key
<i>TARA</i>	Tare
<i>R.TARA</i>	Reset tare value
<i>RES.TOT.</i>	Reset totalizer
<i>MP.INP.2</i>	<b>Select function MP input 2</b>
<i>NO.FUNC.</i>	No function
<i>RES.MIN.</i>	Reset MIN value
<i>RES.MAX.</i>	Reset MAX value
<i>R.PEAKS</i>	Reset MIN and MAX values
<i>RES.REL.</i>	Reset Output-Latch (only if output is in memory mode, ALARMx = LATCH)
<i>DISP.HD.</i>	Hold ('freeze') display
<i>LOCALP.</i>	Lock-out limit value setting
<i>LOC.PRG.</i>	Lock-out programming and default setting
<i>LOCKEY</i>	Lock-out limit value setting, programming, default setting and MP-Key
<i>TARA</i>	Tare
<i>R.TARA</i>	Reset tare value
<i>RES.TOT.</i>	Reset totalizer

## 7.5 Totalizer Function

TOTAL	Menu Totalizer
CUT.OFF	Select value for low threshold cut-off
-199.999	Setting range -199999 ... +999999 and decimal point
FACTOR	Select value for multiplication factor
1.00000	Setting range 0.00001 ... 9.99999
SCALE	Select scale factor
x 1	Scale factor x 1, x 0,1, x 0,01, x 0,001 or x 0,0001
DP.TOT.	Select decimal point for totalizer (visual function only)
0	Format 0, 0.0, 0.00, 0.000, 0.0000 or 0.00000

The totalizer function captures the current (instantaneous) measured value every 100 msec. From these values the throughput rate per second is calculated. To convert the throughput rate into other units FACTOR and SCALE are available. Negative measured values are also taken into consideration. A decimal point that is programmed with a current measured value is not taken into consideration. The throughput rate is added into the totalizer memory every second. A dummy decimal point (optical indication only) can be programmed into the totalizer as required.

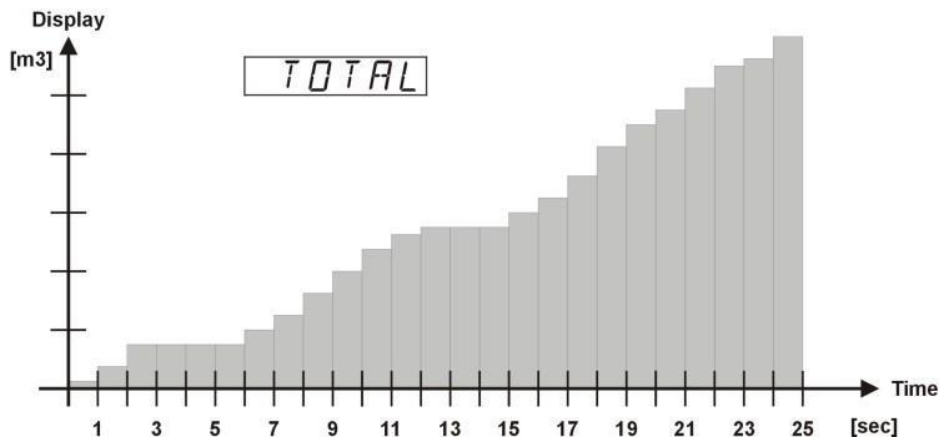
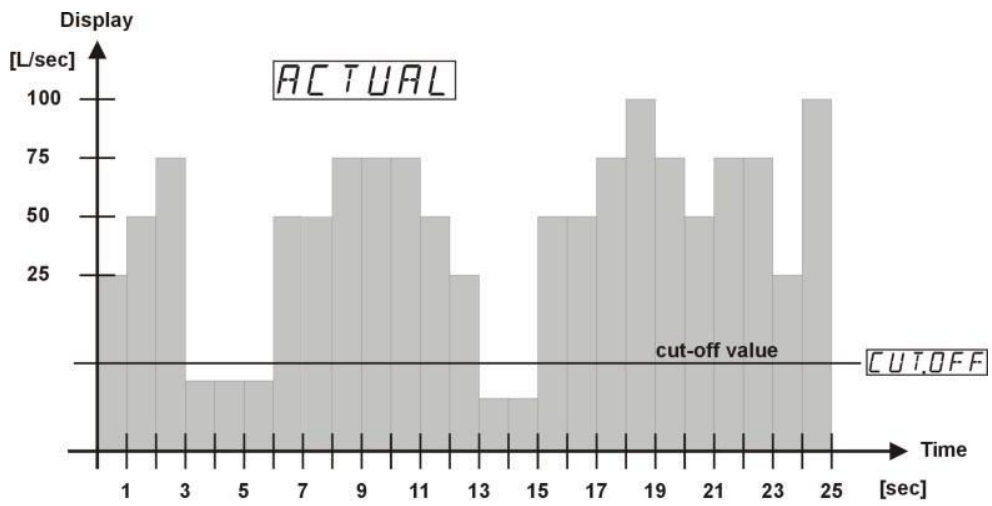

## 7.6 Limit Value (Alarm) Monitoring

<b>ALARM 1</b>	<b>Menu Alarm Output 1</b>
<b>AL.OUT 1</b>	<b>Select operating mode</b>
OFF	OFF
<b>AUTO</b>	Automatic operation
LATCH	Memory latch operation - not with band limitation
<b>ALLOC. 1</b>	<b>Select source value for Alarm output 1</b>
<b>ACTUAL</b>	Current measured value
TOTAL	Totalizer
<b>MD.OUT 1</b>	<b>Select Output triggering</b>
<b>INCR</b>	With incrementing measuring signal
DECR	With decrementing measuring signal
BAND	Band limitation
<b>FM.OUT 1</b>	<b>Select Alarm status</b>
---F--	With alarm: output active
--7---	With alarm: output inactive
<b>ON.HYS. 1</b>	<b>Select ON-hysteresis</b>
0.000	Setting range 0 ... +9999 and decimal point
<b>OF.HYS. 1</b>	<b>Select OFF-hysteresis (only with auto operation)</b>
0.000	Setting range 0 ... +9999 and decimal point
<b>ON.DLY. 1</b>	<b>Select ON-delay</b>
0.0	Setting range 0.0 ... 99.9 [sec]
<b>OF.DLY. 1</b>	<b>Select OFF-delay (only with auto operation)</b>
0.0	Input range 0.0 ... 99.9 [sec]
<b>ALARM 2</b>	<b>Menu Alarm Output 2</b>
<b>AL.OUT 2</b>	<b>Select operating mode</b>
OFF	OFF
<b>AUTO</b>	Automatic operation
LATCH	Memory latch operation

ALLO.C.2	Select source value for Alarm output 2
ACTUAL	Current measured value
TOTAL	Totalizer
M.D.OUT.2	Select Output triggering
INCR	With incrementing measuring signal
DECR	With decrementing measuring signal
BAND	Band limitation
F.M.OUT.2	Select Alarm status
---F--	With alarm: output active
--7---	With alarm: output inactive
ON.HYS.2	Select ON-hysteresis
0.000	Setting range 0 ... +9999 and decimal point
OF.HYS.2	Select OFF-hysteresis (only with auto operation)
0.000	Setting range 0 ... +9999 and decimal point
ON.DLY.2	Select ON-delay
0.0	Setting range 0.0 ... 99.9 [sec]
OF.DLY.2	Select OFF-delay (only with auto operation)
0.0	Input range 0.0 ... 99.9 [sec]

### 7.6.1 Explanatory notes

INCR	ON switching point = limit value + ON hysteresis OFF switching point = limit value – OFF hysteresis	
DECR	ON switching point = limit value – ON hysteresis OFF switching point = limit value + OFF hysteresis	
BAND	An alarm is triggered, if the measured value falls outside a defined range (Band). Upper switching point = limit value + ON hysteresis Lower switching point = limit value – OFF hysteresis	
---F--	An alarm causes the output to become active (Relay energized, LED ON)	
--7---	An alarm causes the output to become inactive (Relay not energized, LED OFF)	
PW.DELY.	LATCH	In memory latch operation the status of the outputs is stored in the event of a Power OFF condition and then immediately restored at the next Power ON.
PW.DELY.	AUTO	In auto operation the status of the outputs is not saved in the event of a Power OFF condition. At the next Power ON the limit values are not processed until after the expiration of the start delay (PW.DELY)



7.6.2 Control with incrementing measuring signal

**INCR**

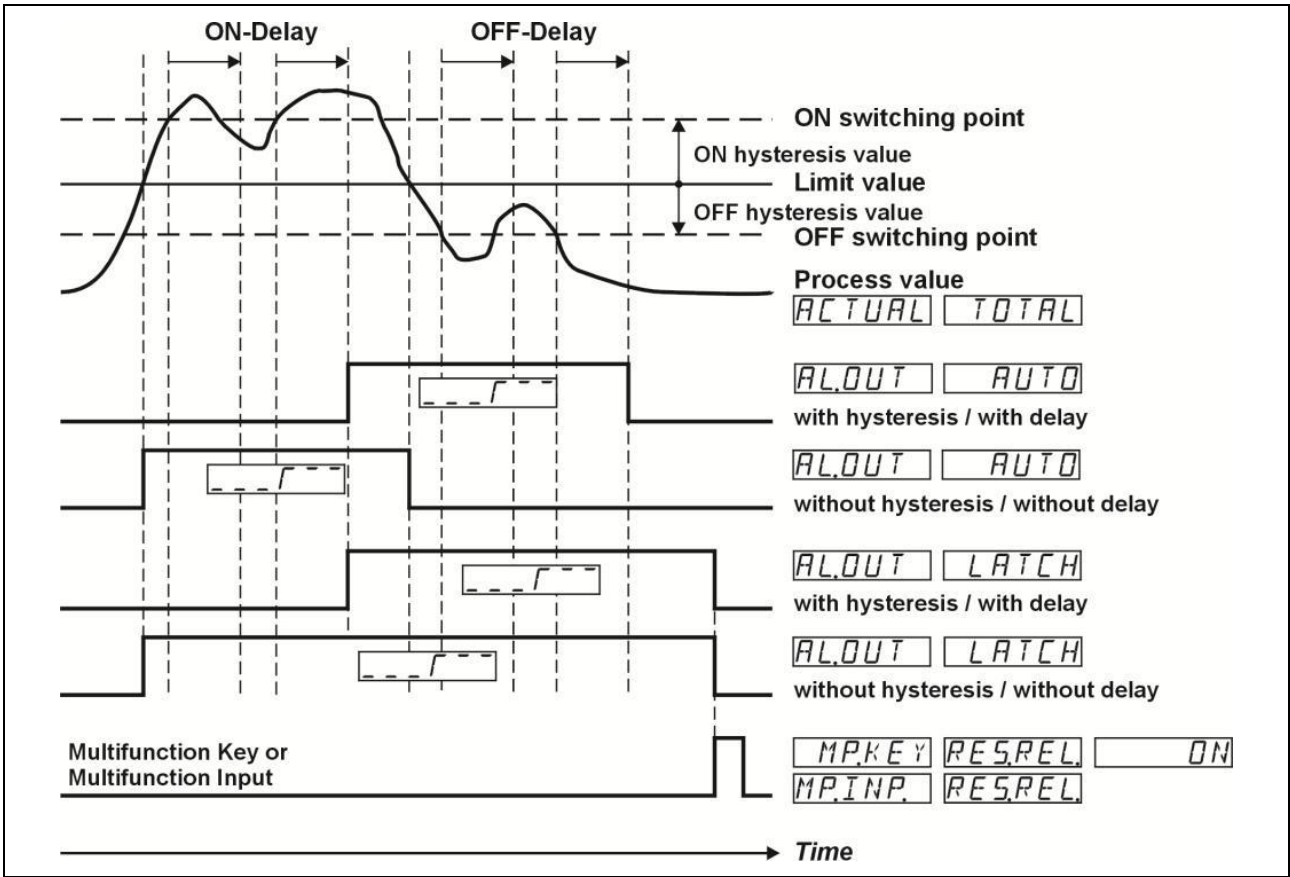

7.6.3 Control with decrementing measuring signal

**DECR**

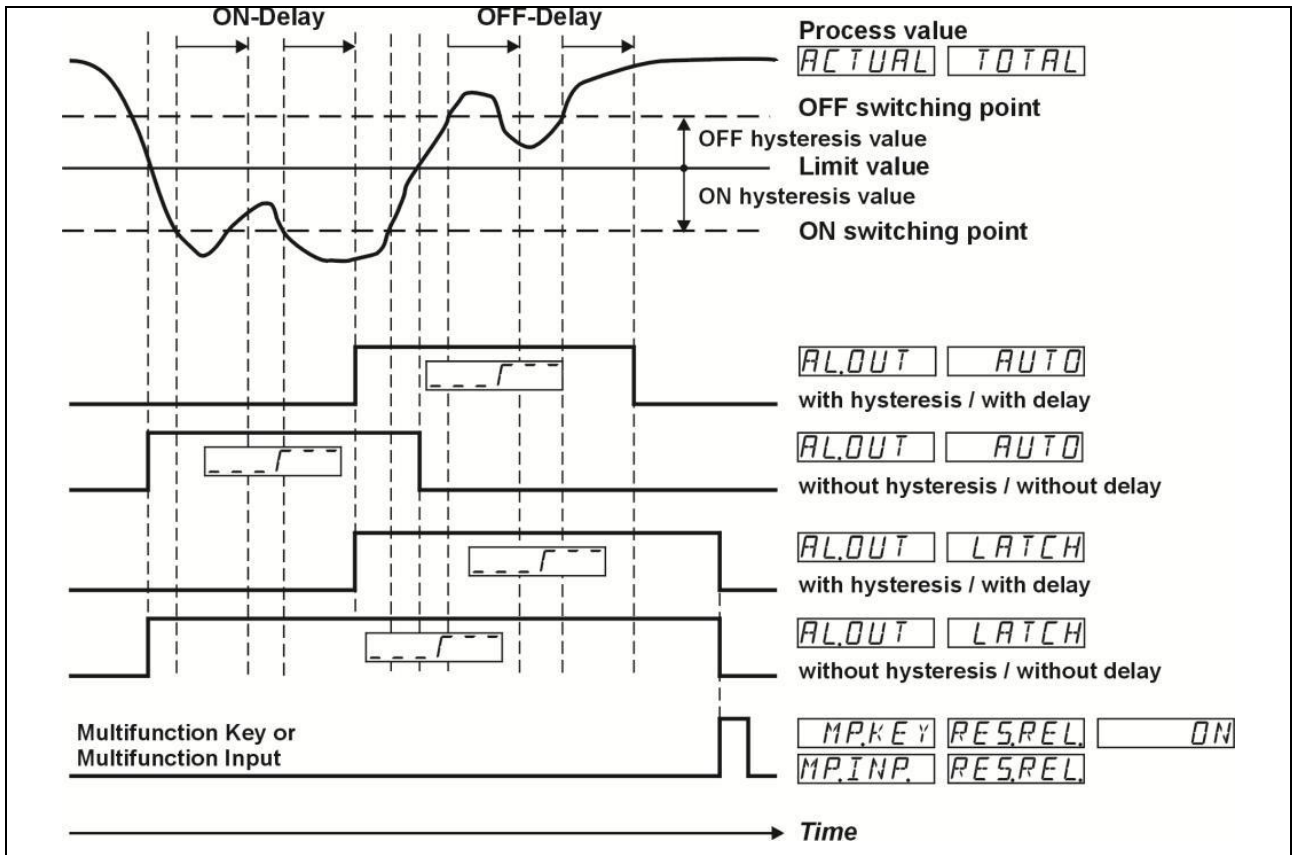

### 7.6.4 Control with Band Limitation

BAND

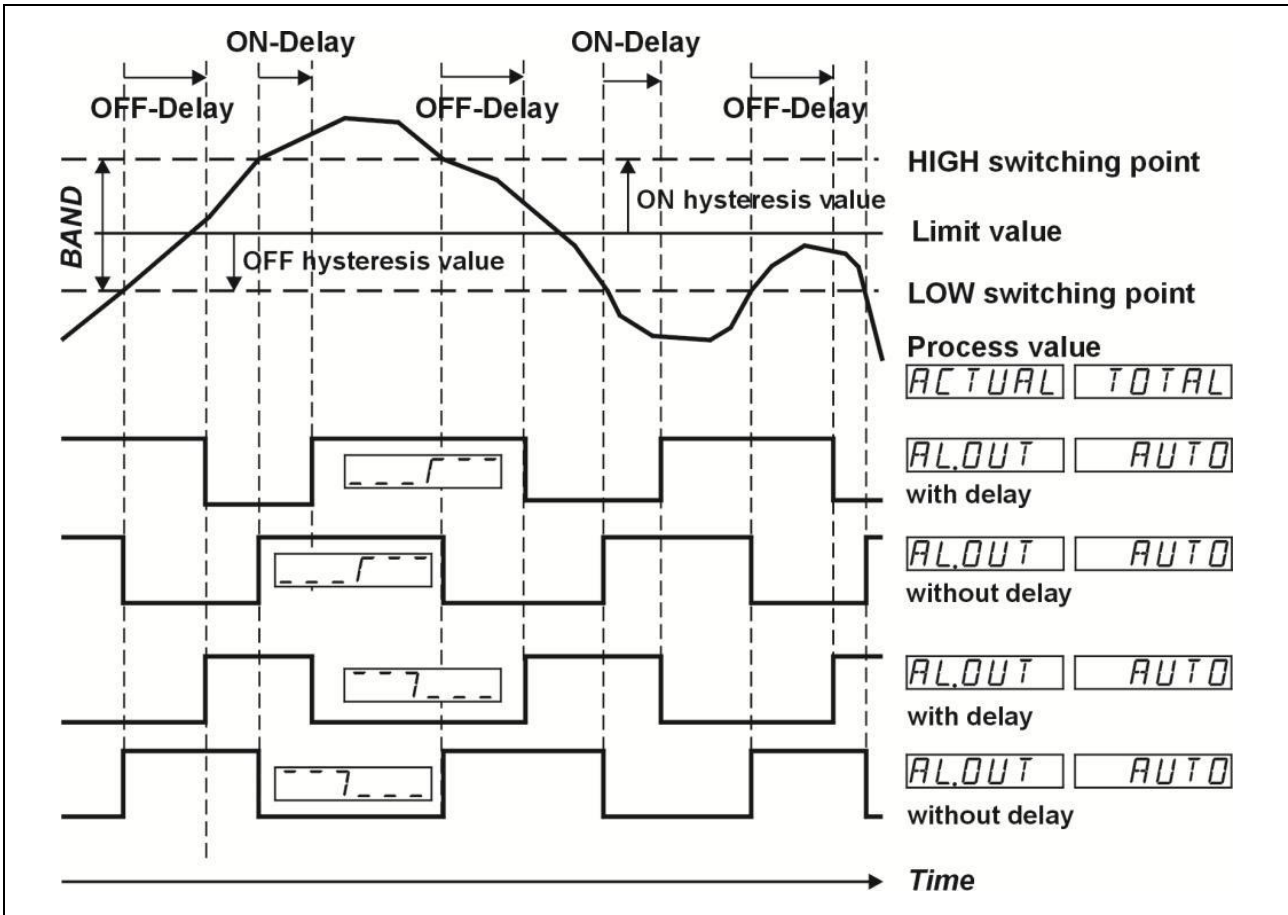

## 7.7 Monitoring of the Measuring Circuit

Measuring Range	Lower Display Range Limit	Upper Display Range Limit	Lower Meas. Range Limit	Upper Meas. Range Limit	Probe or wire short circuit, Probe or wire break
	DISP.LO	DISP.HI	LO.LIM	HI.LIM	
0 ... 10 V	■	■	■	■	–
2 ... 10 V	■	■	■	■	■ (< 1 V)
-10 V / +10 V	■	■	■	■	–
0 ... 20 mA	■	■	■	■	–
4 ... 20 mA	■	■	■	■	■ (< 2 mA)
Indication	-1999.99 blinking	9999.99 blinking	UNDERF. blinking	OVERFL. blinking	SENSOR blinking

(■ = is detected)

## 8. Technical Specifications

<b>General Data</b>	
Display:	6-digit, 14 segment LED
Digit height:	14 mm
Data retention:	> 10 years, EEPROM
Operation:	5 keys
<b>Measuring signal inputs</b>	
Sampling rate:	10 readings/sec
<b>Voltage input</b>	
Programmable ranges:	0 ... 10 V, 2 ... 10 V, $\pm 10$ V
Measuring range:	-10,5 ... +10,5 V
Resolution:	0,4 mV ( $\pm 15$ Bit)
Measuring accuracy:	typ. 0,02 % v. Mb
@ 23°C:	max. $\leq 0,05$ % v. Mb
Temperature drift:	< 100 ppm/K
Input resistance:	1 M $\Omega$
Maximum voltage:	30 V
<b>Current input</b>	
Programmable ranges:	0 ... 20 mA, 4 ... 20 mA
Measuring range:	-0,5 ... 21 mA
Resolution:	1 $\mu$ A (> 14 Bit)
Measuring accuracy:	typ. 0,02 % v. Mb
@ 23°C:	max. $\leq 0,05$ % v. Mb
Temperature drift:	< 100 ppm/K
Input resistance:	22 $\Omega$ + PTC 25 $\Omega$
Voltage drop:	ca. 1,8 V @ 20 mA
Maximum current:	max. 60 mA
<b>Control inputs MPI 1 / MPI 2</b>	
Quantity:	2 optocoupler inputs with programmable function
Switching levels:	Low: < 2 V, High: > 4 V (max. 30 V)
Pulse length:	> 100 ms
<b>Alarm outputs</b>	
Relays:	dry change-over contacts
Switching voltage:	max. 250 V AC / 125 V DC, min. 5 V AC / V DC
Switching current:	max. 5 AAC / ADC, min. 10 mA
Switching capacity:	max. 1250 VA / 150 W
Mechanical service life (switching cycles)	1 x 10 <sup>7</sup>
No. of switching cycles at 5 A / 250 V AC	5x10 <sup>4</sup>
No. of switching cycles at 5 A / 30 V DC	5x10 <sup>4</sup>

<b>Supply voltage</b>	
AC supply:	90 ... 260 V AC / max. 9 VA, 50 / 60 Hz
External fuse protection:	T 0,1 A
DC supply (in-built galvanic isolation)	10 ... 30 V DC / max. 3,5 W with reverse polarity protection
External fuse protection:	T 0,4 A
Mains hum suppression	50 Hz or 60 Hz, programmable
<b>Sensor supply voltage</b>	
AC supply:	24 V DC $\pm$ 15 %, 30 mA and 15 V DC $\pm$ 1 %, 25 mA
DC supply:	15 V DC $\pm$ 1 %, 25 mA only
<b>Climatic conditions</b>	
Operating temperature:	-20°C ... +65°C (-4°F ... +149°F)
Storage temperature:	-25°C ... +75°C (-13°F ... +167°F)
Relative humidity	R.H. 93 % at +40°C (104°F), non-condensing
Altitude:	up to 2000 m (6,562 ft)
<b>EMC</b>	
Noise immunity:	EN 61000-6-2 (with shielded signal and control cables)
Noise emission:	EN 55011 Class B
<b>Device safety</b>	
Designed to:	EN61010 part 1
Protection class:	Protection class 2
Application area:	Pollution level 2
<b>Mechanical data</b>	
Housing:	Panel mount housing to DIN 43 700, RAL 7021
Dimensions:	96 x 48 x 102 mm (3.78 x 1.89 x 4.02")
Panel cut out:	92+0,8 x 45+0,6 mm (3.62+0.03" x 1.77+0.23")
Installation depth:	ca. 92 mm (3.62") including terminals
Weight:	ca. 180 g
Protection:	IP 65 (front)
Housing material:	Polycarbonate UL94 V-2
Vibration resistance EN60068-2-6:	10 - 55 Hz / 1 mm / XYZ, 30 min in each direction
Shock resistance: EN60068-2-27 EN60068-2-29	100G / XYZ, 3 times in each direction 10G / 6 ms / XYZ, 2000 times in each direction
Cleaning:	The front of the unit should only be cleaned using a damp (water!) cloth.
<b>Connections</b>	
Supply voltage and outputs:	Plug-in screw terminal 8-pos., RM5.00, Core cross section max. 2,5 mm <sup>2</sup> / AWG 14
Signal and control inputs:	Plug-in screw terminal 9-pos. RM 3,50, Core cross section max. 1,5 mm <sup>2</sup> / AWG 16

## 9. Dimensional Drawings

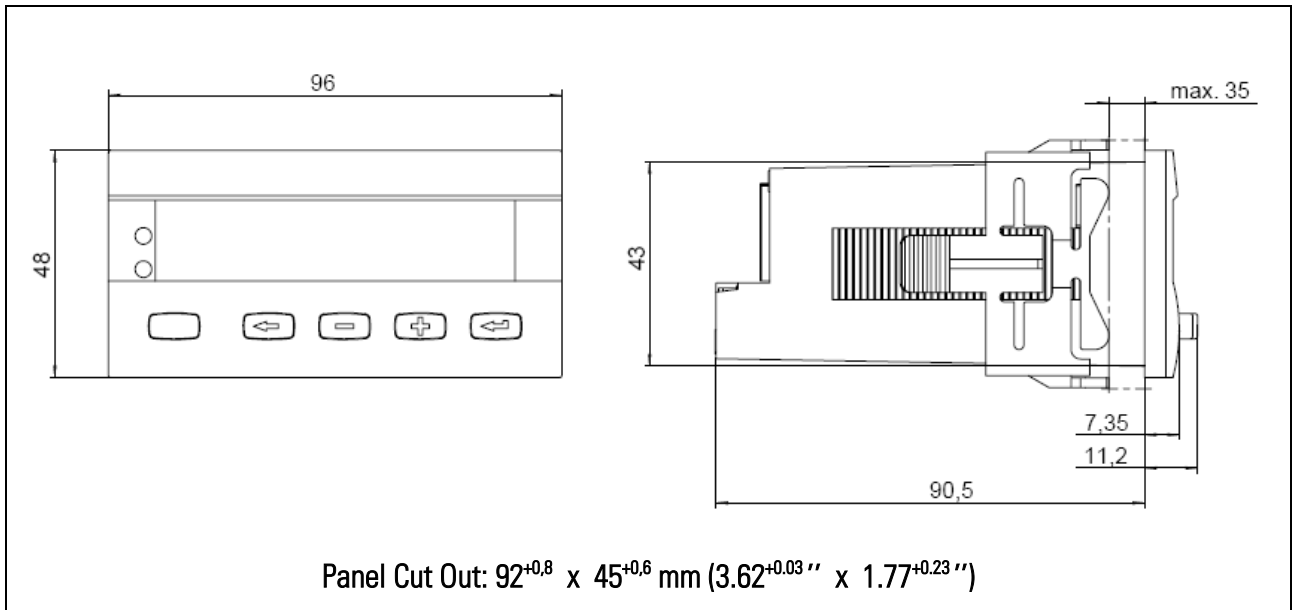

# 10. Help Texts

PROG.	NO	NO PROGRAMMING
PROG.	YES	START PROGRAMMING
HLP.TXT.		MAIN MENU SELECT HELPTXT
HLP.TXT.	ON	HELPTXTS ON
HLP.TXT	OFF	HELPTXTS OFF
SL.LANG.	DE	SPRACHE DEUTSCH
SL.LANG.	EN	LANGUAGE ENGLISH
INPUT.		MAIN MENU SIGNAL INPUT
RANGE	0-10V	VOLTAGE INPUT RANGE 0-10V
RANGE	2-10V	VOLTAGE INPUT RANGE 2-10V
RANGE	-10.10V	VOLTAGE INPUT RANGE -10V/+10V
RANGE	0-20MA	CURRENT INPUT RANGE 0-20MA
RANGE	4-20MA	CURRENT INPUT RANGE 4-20MA
LO.LIM.		LOWER INPUT RANGE LIMIT
HI.LIM.		UPPER INPUT RANGE LIMIT
DP.	0	NO DECIMAL POINT
DP.	0.0	DECIMAL POINT 0.0
DP.	0.00	DECIMAL POINT 0.00
DP.	0.000	DECIMAL POINT 0.000
DP.	0.0000	DECIMAL POINT 0.0000
DP.	0.00000	DECIMAL POINT 0.00000
INP.LO.		INPUT START VALUE
DISP.LO.		DISPLAY START VALUE
INP.HI.		INPUT END VALUE
DISP.HI.		DISPLAY END VALUE
FILTER		INPUT FILTER
PW.DELY.		POWER-ON DELAY FOR OUTPUTS [SEC]
PW.FREQ.	50HZ	POWER LINE FREQUENCY 50HZ
PW.FREQ.	60HZ	POWER LINE FREQUENCY 60HZ
LINEAR.		MAIN MENU LINEARIZATION
LINEAR.	NO	LINEARIZATION OFF
LINEAR.	YES	LINEARIZATION ON
NUM.PNT.		NUMBER OF LINEARIZATION POINTS
INP.01		INPUT VALUE NO.1
DISP.01		DISPLAY VALUE NO.1
to		
INP.10		INPUT VALUE NO.10
DISP.10		DISPLAY VALUE NO.10
MP.KEY		MAIN MENU MP-BUTTON
TARA	OFF	FUNCTION TARA OFF
TARA	ON	FUNCTION TARA ON
RES.MIN.	OFF	FUNCTION RESET MIN VALUE OFF
RES.MIN.	ON	FUNCTION RESET MIN VALUE ON
RES.MAX.	OFF	FUNCTION RESET MAX VALUE OFF
RES.MAX.	ON	FUNCTION RESET MAX VALUE ON
RES.REL.	OFF	FUNCTION RESET OUTPUT-LATCH OFF
RES.REL.	ON	FUNCTION RESET OUTPUT-LATCH ON

RES.TOT.	OFF	FUNCTION RESET TOTALIZER VALUE OFF
RES.TOT.	ON	FUNCTION RESET TOTALIZER VALUE ON
MP.INP.		MAIN MENU MP-INPUTS
MP.INP.x	NO.FUNC.	NO FUNCTION
MP.INP.x	RES.MIN.	FUNCTION RESET MIN VALUE
MP.INP.x	RES.MAX.	FUNCTION RESET MAX VALUE
MP.INP.x	R.PEAKS	FUNCTION RESET MIN/MAX VALUE
MP.INP.x	RES.REL.	FUNCTION RESET OUTPUT-LATCH
MP.INP.x	DISP.HD.	FUNCTION DISPLAY HOLD
MP.INP.x	LOC.ALAR.	FUNCTION LOCK EDITING ALARM VALUES
MP.INP.x	LOC.PRG.	FUNCTION LOCK PROGRAMMING
MP.INP.x	LOC.KEY	FUNCTION LOCK KEYS
MP.INP.x	TARA	FUNCTION TARA
MP.INP.x	R.TARA	FUNCTION RESET TARA VALUE
MP.INP.x	RES.TOT	FUNCTION RESET TOTALIZER VALUE
TOTAL		MAIN MENU TOTALIZER
CUT.OFF		CUT OFF VALUE
FACTOR		MULTIPLICATION FACTOR TOTALISER
SCALE	x1	SCALING FACTOR TOTALIZER X1
SCALE	x0.1	SCALING FACTOR TOTALIZER X0.1
SCALE	x0.01	SCALING FACTOR TOTALIZER X0.01
SCALE	x0.001	SCALING FACTOR TOTALIZER X0.001
SCALE	x0.0001	SCALING FACTOR TOTALIZER X0.0001
DP.TOT.	0	NO DECIMAL POINT
DP.TOT.	0.0	DECIMAL POINT TOTALISER 0.0
DP.TOT.	0.00	DECIMAL POINT TOTALISER 0.00
DP.TOT.	0.000	DECIMAL POINT TOTALISER 0.000
DP.TOT.	0.0000	DECIMAL POINT TOTALISER 0.0000
DP.TOT	0.00000	DECIMAL POINT TOTALISER 0.00000
ALARMx		MAIN MENU ALARM x
AL.OUTx	OFF	ALARM x OFF
AL.OUTx	AUTO	AUTOMATIC MODE OF ALARM OUTPUT x
AL.OUTx	LATCH	LATCH MODE OF ALARM OUTPUT x
ALLOC.x	ACTUAL	ACTUAL VALUE TO ALARM
ALLOC.x	TOTAL	TOTALIZER TO ALARM
MD.OUTx	INCR	ALARM x ACTIVE AT INCREASING INPUT SIGNAL
MD.OUTx	DECR	ALARM x ACTIVE AT DECREASING INPUT SIGNAL
MD.OUTx	BAND	ALARM x BAND LIMITATION
FM.OUTx		OUTPUT ACTIVE AT ALARM
FM.OUTx		OUTPUT INACTIVE AT ALARM
ON.HYS.x		SWITCH ON HYSTERESIS ALARM x
OF.HYS.x		SWITCH OFF HYSTERESIS ALARM x
ON.DLY.x		ON DELAY ALARM x [SEC]
OF.DLY.x		OFF DELAY ALARM x [SEC]
END.PRG.	NO	REPEAT PROGRAMMING
END.PRG.	YES	EXIT PROGRAMMING AND STORE DATA
-1.9.9.9.9.9		DISPLAYRANGE UNDERFLOW
9.9.9.9.9.9.		DISPLAYRANGE OVERFLOW
OVERFL.		OVERFLOW UPPER INPUT RANGE LIMIT
UNDERF.		UNDERFLOW LOWER INPUT RANGE LIMIT

SENSOR		SENSOR ERROR
--------	--	--------------